

INSTRUCTION MANUAL

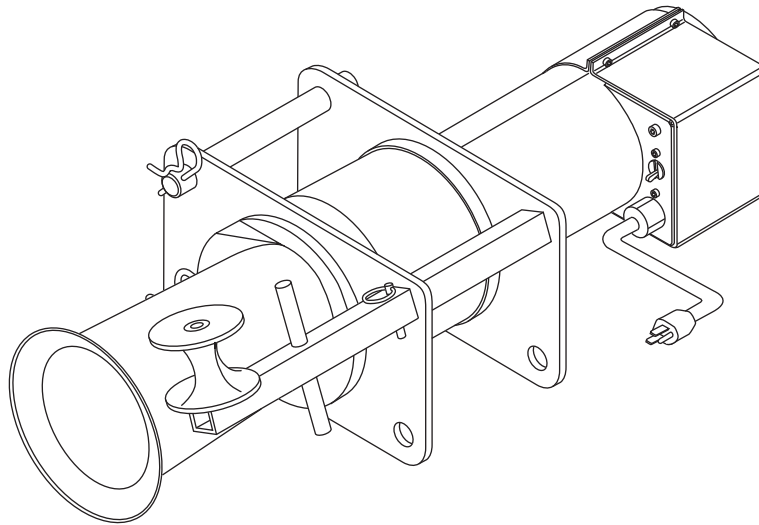

Ultra Tugger[®] 8 Cable Puller and Pulling Packages

with Serial Code ABJ



Read and understand all of the instructions and safety information in this manual before operating or servicing this tool.

Table of Contents

Description	3	Setup:	
Purpose	3	Pipe Adapter	25-27
Important Safety Information	4-7	T-Stand	28
Grounding Instructions	8	Wheeled Carriage	29
Identification	9-10	Mounting Components:	
Specifications	11	Boom with Nose Unit	30
Cable Pulling Glossary	12	Booms with Elbow Unit and Nose Unit.....	31
Cable Pulling Principles:		Slip-in Coupler	32
Cable Pulling Systems	13	Straddling the Conduit with Slip-in Coupler	32
Pulling Theory	14	Chain Mount	33-34
Cable Pulling Forces:		Floor Mount	35
At the Cable Puller Anchoring System	15	Installation.....	35
At the Capstan	16	Operation.....	36
At the Pulling Rope	17	Removing Cable	37
At the Connectors	18	Maintenance.....	38-39
At the Sheaves	19	Exploded Views/ Parts Lists:	
Tailing the Rope:		Ultra Tugger (with wiring diagram)	40-41
Control of the Pull	20	Gearmotor (50006460).....	42-43
Amount of Tailing Force	20	Motor (50006649)	44
Number of Wraps of Rope around the Capstan ..	20	Force Gauge	45
Preventing Rope Overlap	20	Accessories	46-52
Summary of Cable Pulling Principles.....	21		
Planning the Pull.....	21		
Typical Setups:			
Pipe Adapter	22		
Chain Mount	22		
Floor Mount	22		
T-Stand	23		
Wheeled Carriage	24		



Description

The Greenlee Ultra Tugger® cable puller is intended to be used to pull cable through conduit and in tray. The Ultra Tugger will develop 35.6 kilo-Newtons (8000 lb) of pulling force. See a Greenlee catalog for sheaves, pulling rope, and other cable pulling accessories to create an entire cable pulling system.

No single manual can provide instructions for every possible cable pulling application; this manual contains general information necessary to accomplish cable pulls of many different setups.

Safety

Safety is essential in the use and maintenance of Greenlee tools and equipment. This instruction manual and any markings on the tools provide information for avoiding hazards and unsafe practices related to use of this tool. Observe all of the safety information provided.

Purpose

This manual is intended to familiarize all personnel with Greenlee 6800-series Ultra Tugger cable pullers.

Keep this manual available to all personnel.

Replacement manuals are available upon request at no charge.

All specifications are nominal and may change as design improvements occur. Greenlee Textron Inc. shall not be liable for damages resulting from misapplication or misuse of its products. Ultra Tugger is a registered trademark of Greenlee Textron Inc. Versi-Boom is a trademark of Greenlee Textron Inc. Loctite and 242 are registered trademarks of Loctite Corporation. Texaco is a registered trademark of Texaco Inc.

KEEP THIS MANUAL



IMPORTANT SAFETY INFORMATION



SAFETY ALERT SYMBOL

This symbol is used to call your attention to hazards or unsafe practices which could result in an injury or property damage. The signal word, defined below, indicates the severity of the hazard. The message after the signal word provides information for preventing or avoiding the hazard.

⚠ DANGER

Immediate hazards which, if not avoided, **WILL** result in severe injury or death.

⚠ WARNING

Hazards which, if not avoided, **COULD** result in severe injury or death.

⚠ CAUTION

Hazards or unsafe practices which, if not avoided, **MAY** result in injury or property damage.



⚠ DANGER

Do not operate the cable puller in a hazardous environment. Hazards include flammable liquids and gases. Failure to observe this warning will result in severe injury or death.



⚠ WARNING

Electric shock hazard:
Disconnect the cable puller from the power supply before servicing. Failure to observe this warning could result in severe injury or death.

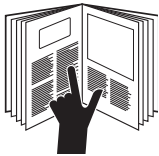

⚠ DANGER

Read and understand all of the instructions and safety information in this manual before operating or servicing this tool.

Failure to observe this warning will result in severe injury or death.





IMPORTANT SAFETY INFORMATION

	⚠ WARNING
	Inspect and verify the maximum load-bearing capacity or maximum strength of all structural supports, pulling system components and anchoring systems before setting up the puller. Any component that cannot withstand the maximum cable-pulling forces could break and strike nearby personnel with sufficient force to cause severe injury or death.

	⚠ WARNING
	Do not allow anything other than the pulling rope to contact the capstan. A grip, swivel, or other component could break and strike nearby personnel with great force. Failure to observe this warning could result in severe injury or death.

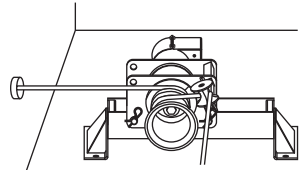
	⚠ WARNING
	Do not stand directly under a vertical pull. Cable could fall suddenly from the conduit. Failure to observe this warning could result in severe injury or death.

⚠ WARNING
Locate the puller so that it is close to the conduit. Rope, cable, or connectors can break under tension, causing the rope to whip violently. Failure to observe this warning could result in severe injury or death.
 

⚠ WARNING
An under-rated or worn rope may break and whip violently. Use a double-braided composite rope with the following characteristics:
<ul style="list-style-type: none"> • Maximum Rated Capacity: at least 35.6 kN (8000 lb) • Average Breaking Strength: at least 143 kN (32,000 lb)
Failure to observe this warning could result in severe injury or death.



IMPORTANT SAFETY INFORMATION

⚠ WARNING

- Check the condition of the entire rope before use. A worn or damaged rope can break under tension and whip violently.
- Do not maintain a stationary rope on a rotating capstan. The wear generated may cause the rope to break under tension and whip violently.

Failure to observe these warnings could result in severe injury or death.

⚠ WARNING

Rope, cable, or a connecting device can break under tension, causing the rope to whip violently.

- Do not allow any unnecessary personnel to remain in the area during the pull.
- Do not allow any personnel to stand in line with the pulling rope.

Failure to observe these warnings could result in severe injury or death.

⚠ WARNING

Attach the pulling rope to the cable with appropriate types of connectors as described in this manual. Select connectors with a maximum-rated capacity of 35.6 kN (8000 lb). An under-rated connector can break under tension.

Failure to observe this warning could result in severe injury or death.

⚠ WARNING

Do not allow the rope to become overlapped on the capstan. If an overlap begins to develop, relax the tailing force immediately and shut off the cable puller.

Failure to observe this warning could result in severe injury or death.

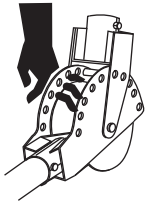

⚠ WARNING

Shear Point:

Do not put fingers through holes in elbow unit. Rotating parts may cut off fingers.

Failure to observe this warning could result in severe injury or death.



⚠ WARNING

Do not operate without chain guards in place.

Failure to observe this warning could result in severe injury or death.



⚠ WARNING

Keep hands away from the capstan. Rope at the capstan can crush a hand.

Failure to observe this warning could result in severe injury or death.

⚠ WARNING

Use this tool for manufacturer's intended purpose only. Do not use the cable puller as a hoist or winch.

- The cable puller cannot lower a load.
- The load may fall.

Failure to observe this warning could result in severe injury or death.



⚠ WARNING

Do not wrap rope around hands, arms, waist or other body parts. Do not stand in spent coils or tailed rope. Hold rope so that it may be released quickly.

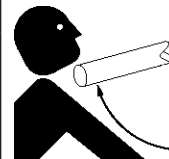

⚠ WARNING

Always lock boom components in place during assembly or disassembly. Adding and removing components may change rotation. Parts may strike nearby personnel.



IMPORTANT SAFETY INFORMATION

⚠ WARNING

Inspect puller and accessories before use. Replace any worn or damaged components with Greenlee replacement parts. A damaged or improperly assembled item can break and strike nearby personnel with sufficient force to cause severe injury or death.

⚠ WARNING

Entanglement hazard:

- Do not operate the cable puller while wearing loose-fitting clothing.
- Retain long hair.

Failure to observe this warning could result in severe injury or death.

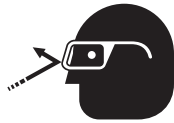

⚠ WARNING

Wear eye protection when using this tool. Failure to wear eye protection could result in severe eye injury from flying debris.

⚠ WARNING

When using the wheeled carriage to transport the Ultra Tugger:

- Keep personnel out of the path of transport.
- Evaluate the terrain of over which the carriage is to move. If in doubt, obtain additional help and move the carriage slowly.
- Do not transport over inclines of more than 15°.
- Do not transport the carriage with boom tubes longer than the supplied 3' and 4' tubes.

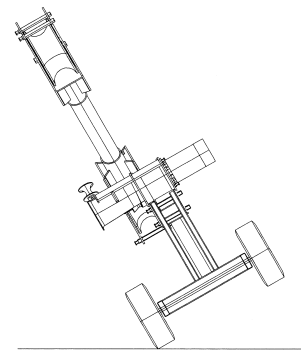



Grounding Instructions

	⚠ WARNING
	<p>Electric shock hazard: Disconnect the cable puller from the power supply before servicing. Failure to observe this warning could result in severe injury or death.</p>

This tool must be grounded. In the event of a malfunction or breakdown, an electrical ground provides a path of least resistance for the electric current. This path of least resistance is intended to reduce the risk of electric shock to the operator.

This tool's electric cord has a grounding conductor and a grounding plug as shown. Do not modify the plug. Connect the plug to receptacle that is properly installed and grounded in accordance with all national and local codes and ordinances. Do not use an adapter.

20-Amp / 115-Volt Plug and Grounded Receptacle

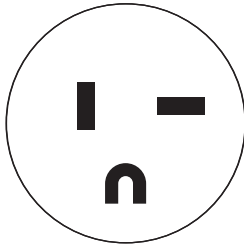

Plug

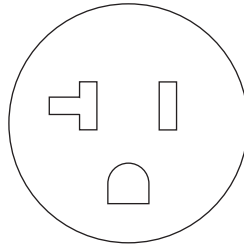

Receptacle



Identification

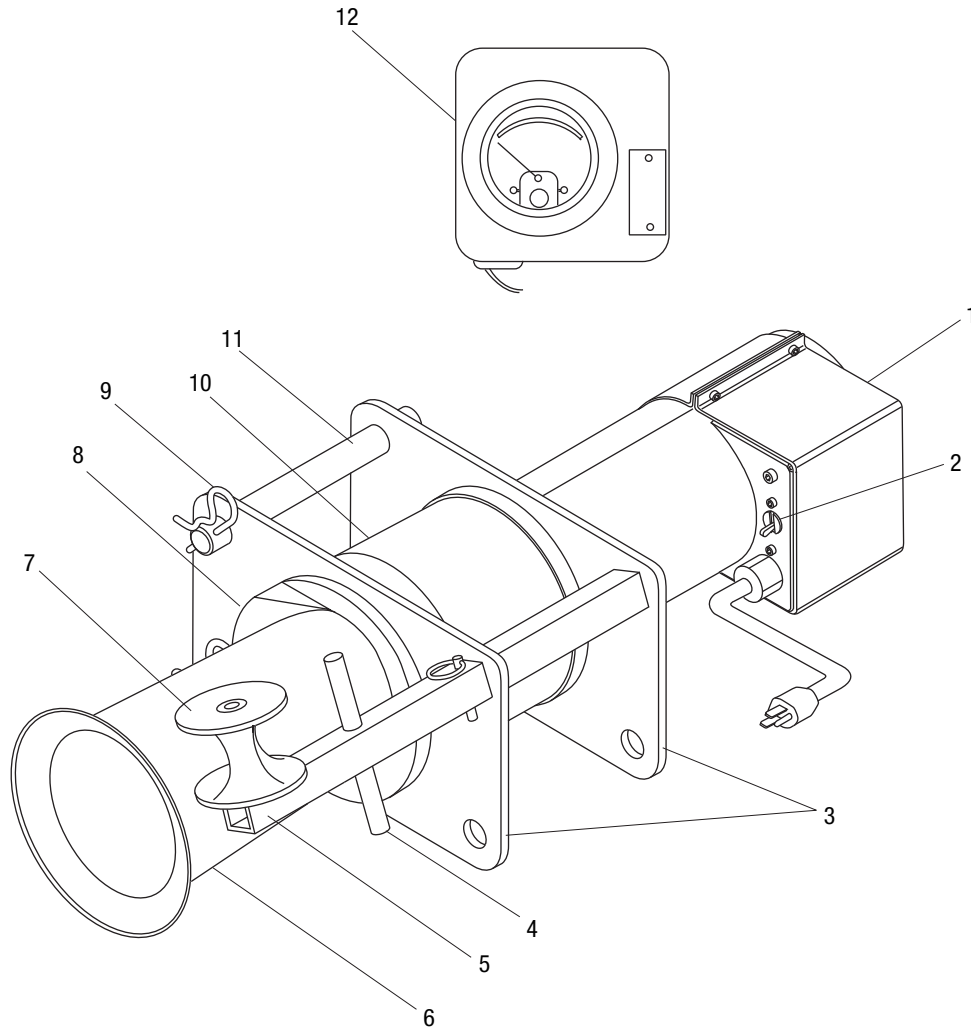

Ultra Tugger Cable Puller

- | | |
|------------------------------|-------------------------------------------|
| 1. Motor | 7. Right Angle Sheave |
| 2. Circuit Breaker/Switch | 8. Rope Ramp |
| 3. Mounting Plates | 9. Hitch Clip |
| 4. Rope Tie-Off | 10. Gearbox |
| 5. Adjustable Sheave Bracket | 11. Mounting Pin |
| 6. Tapered Steel Capstan | 12. Force Gauge with Remote ON/OFF Switch |



Identification (cont'd)

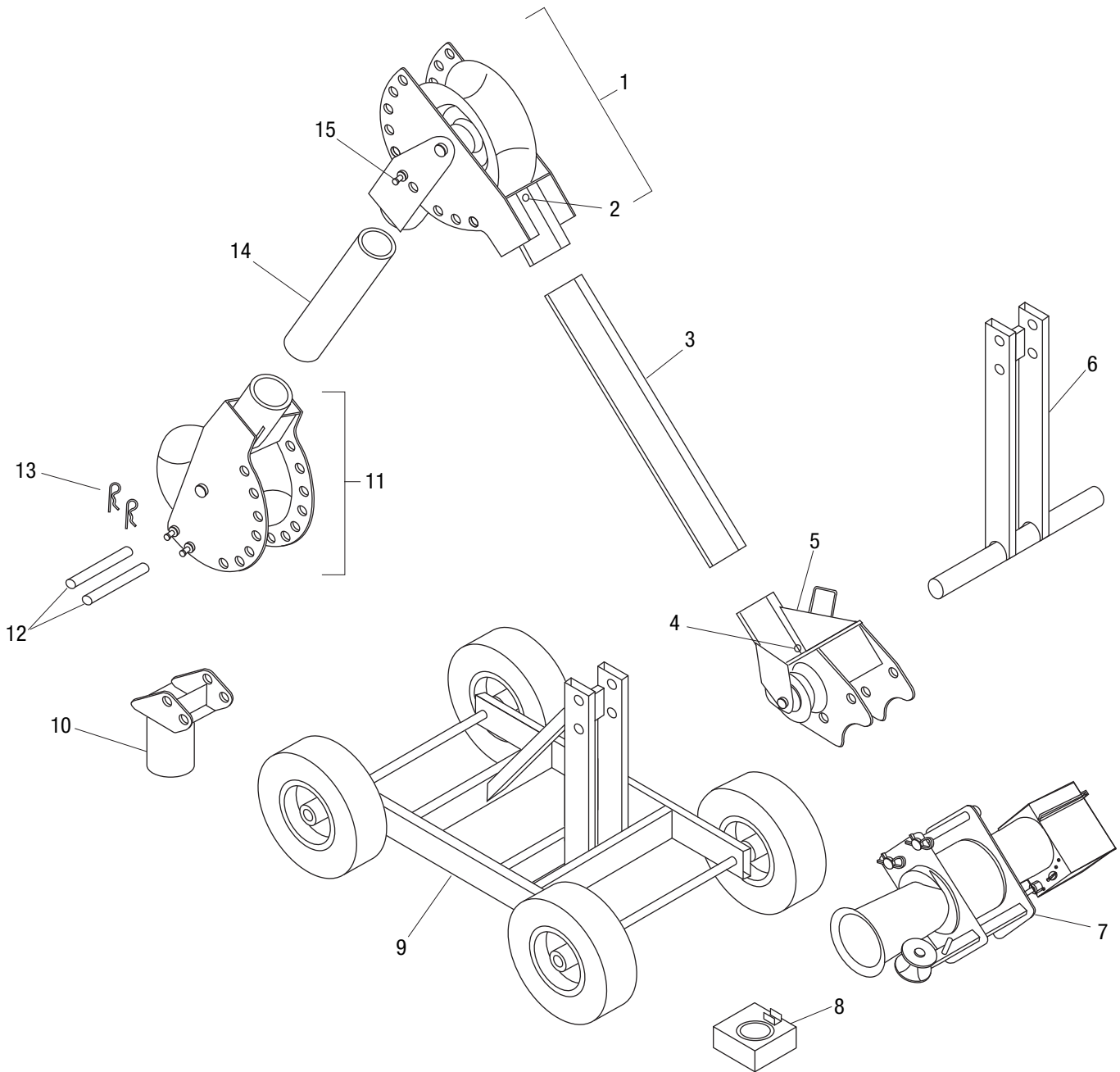

Versi-Boom™ Components

- | | |
|-----------------|---------------------|
| 1. Elbow Unit | 9. Wheeled Carriage |
| 2. Sight Hole | 10. Slip-in Coupler |
| 3. 4' Boom Tube | 11. Nose Unit |
| 4. Sight Hole | 12. Mounting Pins |
| 5. Boom Mount | 13. Hitch Pin Clips |
| 6. T-Stand | 14. 3' Boom Tube |
| 7. Puller | 15. Long Pin |
| 8. Force Gauge | |



Specifications

Weight..... 38 kg (84 lb)

Dimensions:

 Length 29 cm (11.5")

 Width 66 cm (26")

 Height..... 17 cm (6.75")

Motor:

 Voltage 120 VAC, 50/60 Hz, Single Phase

 Current Draw at Full Load 15 Amps

 Sound Level 75 dB at 1 meter

Power Source..... 120 VAC, 60 Hz, 20 Amps, Single Phase

Speed:

 No Load..... 2.74 m/min (9 ft/min)

 8900 Newtons (2000 lb) 2.44 m/min (8 ft/min)

 17.8 kN (4000 lb) 2.29 m/min (7.5 ft/min)

 26.7 kN (6000 lb) 2.13 m/min (7 ft/min)

 35.6 kN (8000 lb) 1.83 m/min (6 ft/min)

Pulling Force:

 0 - 28.9 kN (0 - 6500 lb) Continuous Operation

 28.9 kN - 35.6 kN (6500 - 8000 lb)..... 15 minutes on / 15 minutes off

Pulling Rope:

 Required Rope 7/8" diameter, double-braided, polyester composite

 Average Breaking Strength 143 kN (32,000 lb) minimum



Cable Pulling Glossary

anchoring system

any item or group of items that keeps a cable pulling component in place during the cable pull

capstan

the hollow cylinder of the cable puller that acts on the pulling rope to generate pulling force

coefficient of friction

the ratio that compares two amounts of force: (1) the force needed to move an object over a surface and (2) the force holding the object against the surface
This ratio is used to describe how the capstan and the rope work together.

connector

any item, such as a wire grip, clevis, swivel, or pulling grip, that connects the rope to the cable

direct line of pull

the areas next to the pulling rope and along its path; this includes the areas in front of, in back of, and underneath the rope

maximum rated capacity

the amount of pulling tension that any component can safely withstand, rated in kilo-Newtons (metric) or pounds; the maximum rated capacity of every component must meet or exceed the maximum pulling force of the cable puller

Newton

a metric unit of force, equivalent to .225 pounds of force

pipe adapter sheave

attaches to conduit for pulling or feeding cable

pulling grip

connects the rope to the cable; consists of a wire mesh basket that slides over the cable and grips the insulation

pulling force

the amount of pulling tension developed by the cable puller, rated in Newtons (metric) or pounds; a cable puller is usually described by the maximum pulling force that it can develop

resultant force

any force that is produced when two or more forces act on an object; applies to the sheaves of a cable pulling system

rope ramp

a device that works with a tapered capstan; guides the rope onto the capstan to prevent rope overlap

sheave

a pulley that changes the direction of the rope and cable

stored energy

the energy that accumulates in the pulling rope as it stretches, described in Newton-meters (metric) or foot-pounds

support structure

any stationary object that a cable pulling system component is anchored to, such as a concrete floor (for the floor mount) or an I-beam (for a sheave)

tactile feedback

the way the rope feels as it feeds off of the capstan; the feel of the rope provides information about the progress of the pull to the operator

tail

the portion of the rope that the operator applies force to; this is the rope coming off of the capstan, and is not under the tension of the pull

tailing the rope

the operator's main function; this is the process of applying force to the tail of the pulling rope—see the complete explanation under Principles of Cable Pulling

wire grip

connects the rope to the cable; some use a set screw to clamp onto the conductors of the cable

Cable Pulling Principles

Pulling cable is a complex process. This section of the manual describes and explains four main topics of pulling cable:

- each cable pulling system component
- how these components work together
- forces that are generated
- procedures for the cable puller operator to follow

While reading through this section of the manual, look for components that are shaded in the illustrations. The shading indicates components that are associated with the text.

Greenlee strongly recommends that each member of the cable pulling crew review this section of the manual before each cable pull.

Cable Pulling Systems

Pulling cable requires a system of components. At a minimum, a cable pulling system will include a cable puller, a cable pulling rope, and connectors to join the rope to the cable. Most systems will also include, but are not limited to, a cable puller anchoring system, pulling sheaves and sheave anchoring systems.

The cable puller has a maximum amount of *pulling force*, which is the amount of pulling tension that it develops. Every other component of the pulling system has a *maximum rated capacity*, which is the amount of pulling tension that it can withstand. The maximum rated capacity of every component must meet or exceed the cable puller's maximum pulling force.

Typical Cable Pulling System

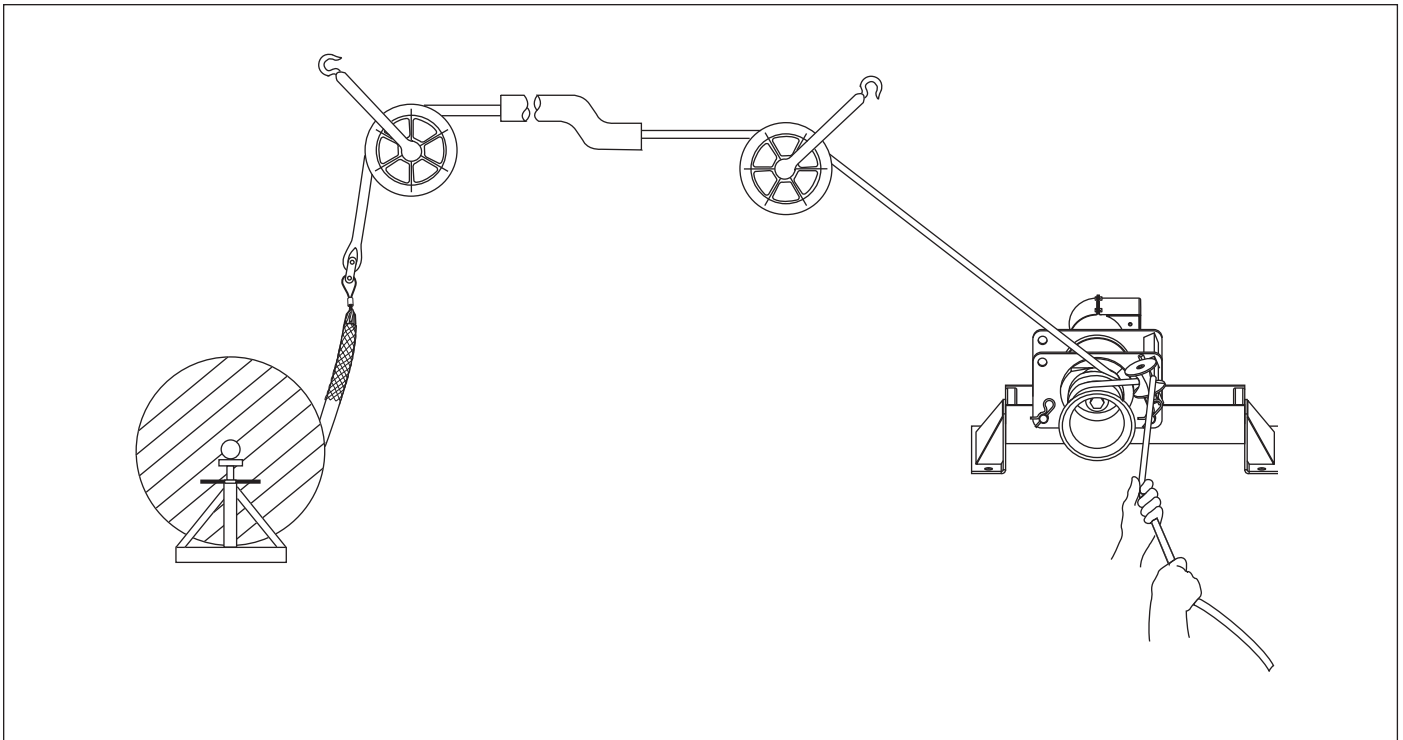



Cable Pulling Principles (cont'd)

Pulling Theory

This section introduces the main ideas involved with pulling cable.

Pulling Resistance

The cable puller must overcome two types of resistance: gravity and friction.

Gravity constantly exerts its force on the vertical portions of the run. When the pulling force is relaxed, gravity attempts to pull the cable downward. Friction develops where the cable contacts the sheaves, conduit and tray. Friction resists any movement, forward or backward, and tends to hold the cables in place.

To accomplish a cable pull, the cable pulling system must develop more force than the combination of gravity and friction.

Generating Pulling Force

To generate pulling force, the capstan works as a *force multiplier*. The operator exerts a small amount of force on the rope. The cable puller multiplies this and generates the pulling force.

This pulling force is applied to the rope, connectors, and cable in order to accomplish the pull. The direction of force is changed, where necessary, with pulling sheaves.

Cable Pulling Theory Illustrated

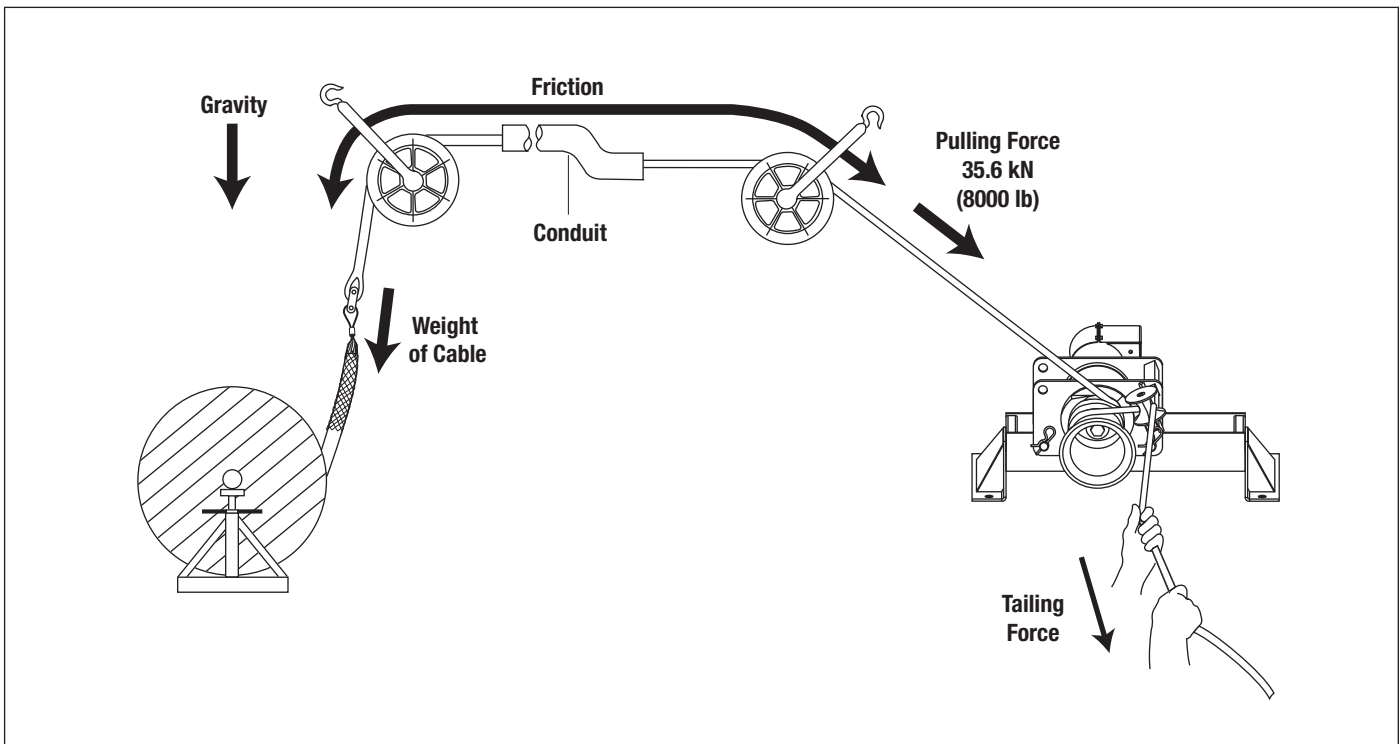



Cable Pulling Principles (cont'd)

Cable Pulling Forces

This section provides detailed explanations and illustrations of the forces that are generated during the cable pull. These explanations are based on the concepts presented in the last section, Pulling Theory.

At the Cable Puller Anchoring System

The cable puller will exert its maximum pulling force on cable puller's anchoring system. It is extremely important the anchoring system can withstand this amount of force. See the instruction manual provided with your anchoring system for proper setup or installation.

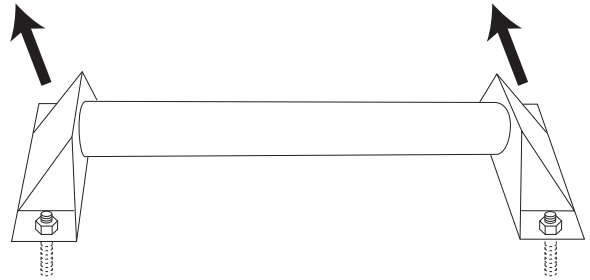

Pulling Force at the Cable Puller's Anchoring System

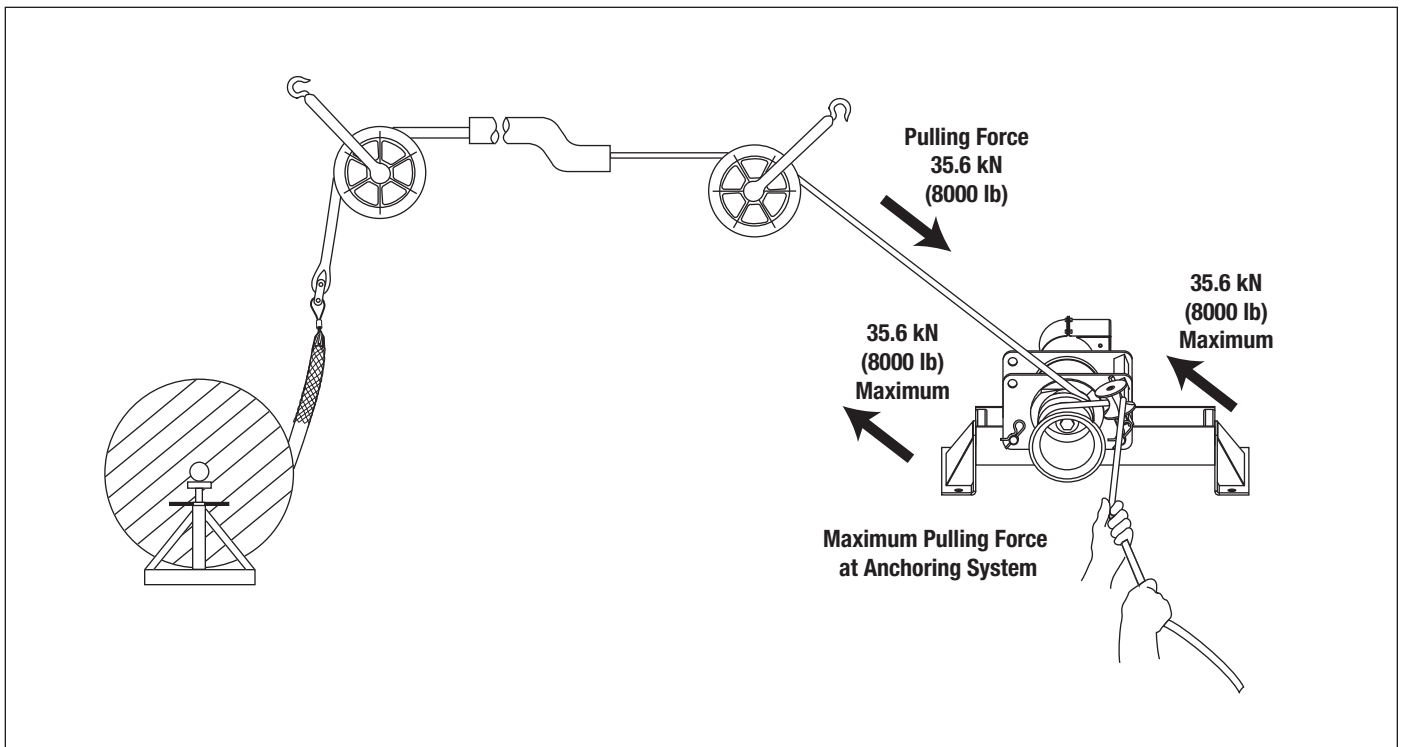



Cable Pulling Principles (cont'd)

Cable Pulling Forces (cont'd)

At the Capstan

The capstan acts as a *force multiplier*. The operator exerts a small amount of tension, or tailing force, on the rope; the capstan multiplies this force to pull the cable. The resultant force depends upon the number of times the rope is wrapped around the capstan, as shown in the formula below.

$$\text{Pulling Force} = \text{Tailing Force} \times e^{0.0175\mu\theta}$$

Where: e = the natural logarithm, or 2.7183

μ = the coefficient of friction between the rope and the capstan *

θ = the number of degrees of wrap of rope around the capstan

* The average value for the coefficient of friction when double-braided composite rope is pulled over a clean dry capstan is 0.125.

The following table is based on the formula above. The input, or tailing force, is constant at 44.5 Newtons (10 lb). Increasing the number of wraps increases the pulling force.

Operator's Tailing Force	Number of Wraps of Rope	Approximate Pulling Force
44.5 N (10 lb)	1	93.4 N (21 lb)
	2	213.5 N (48 lb)
	3	474.9 N (106 lb)
	4	1043.8 N (233 lb)
	5	2293.7 N (512 lb)
	6	5048.9 N (1127 lb)
	7	11.1 kN (2478 lb)

This table shows how the capstan acts as a force multiplier. Because the coefficient of friction depends upon the condition of the rope and capstan, this formula cannot determine an exact amount of pulling force.

The Capstan as a Force Multiplier

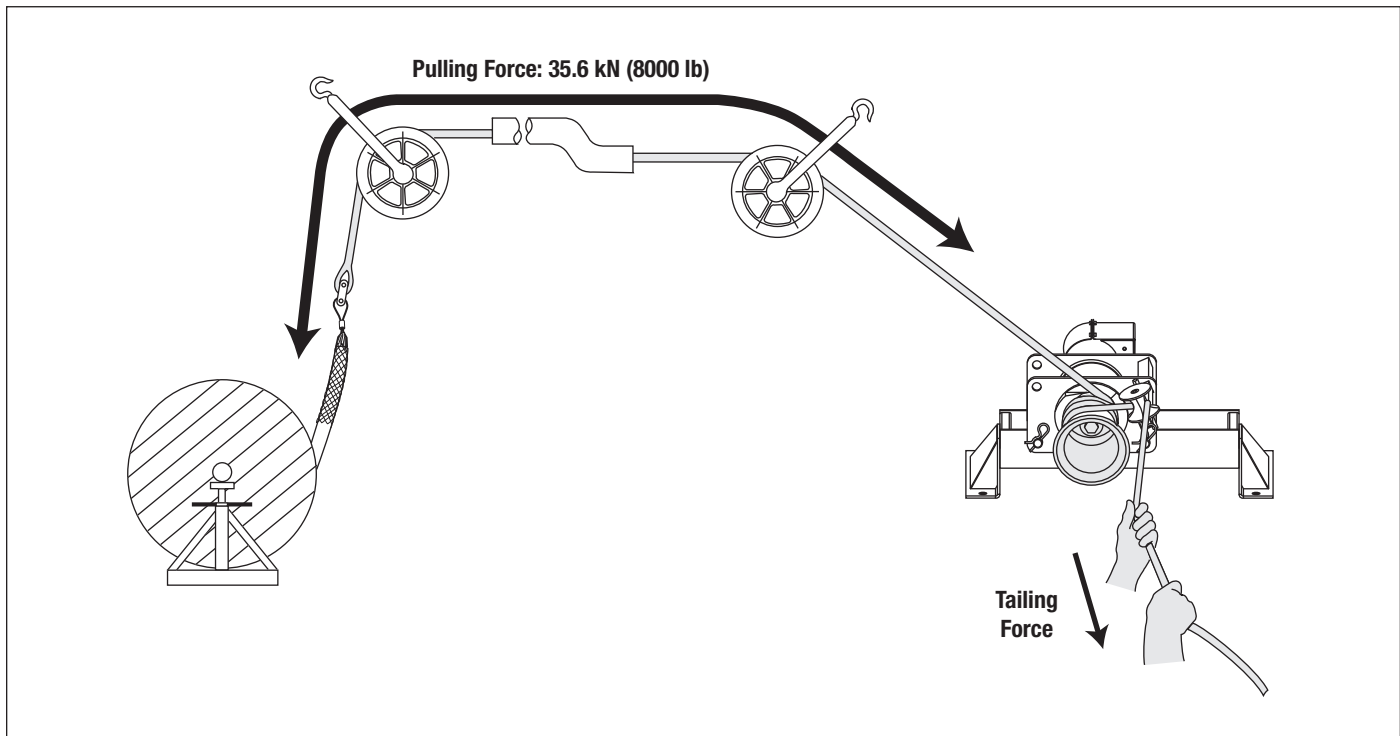



Cable Pulling Principles (cont'd)

Cable Pulling Forces (cont'd)

At the Pulling Rope

The product of a force (f) moving through a distance (d) is energy (f x d), and may be measured in Newton-meters or ft-lb. Energy is stored in a rope when the rope is stretched. This is similar to the way energy is stored in a rubber band when it is stretched. Failure of the rope or any other component of the pulling system can cause a sudden uncontrolled release of the energy stored in the rope.

For example, a 100-meter nylon rope with a 50,000 Newton average breaking strength could stretch 40 meters and store 1,000,000 joules of energy. This is enough energy to throw a 900-kilogram object, such as a small automobile, 113 meters into the air.

A similar double-braided composite rope could store approximately 300,000 joules of energy. This could throw the same object only 34 meters into the air. The double-braided composite rope stores much less energy and has much less potential for injury if it were to break.

Double-braided composite rope is the only type of rope recommended for use with the Ultra Tugger cable puller. Select a double-braided composite rope with an average rated breaking strength of at least 143 kN (32,000 lb).

Stored Energy

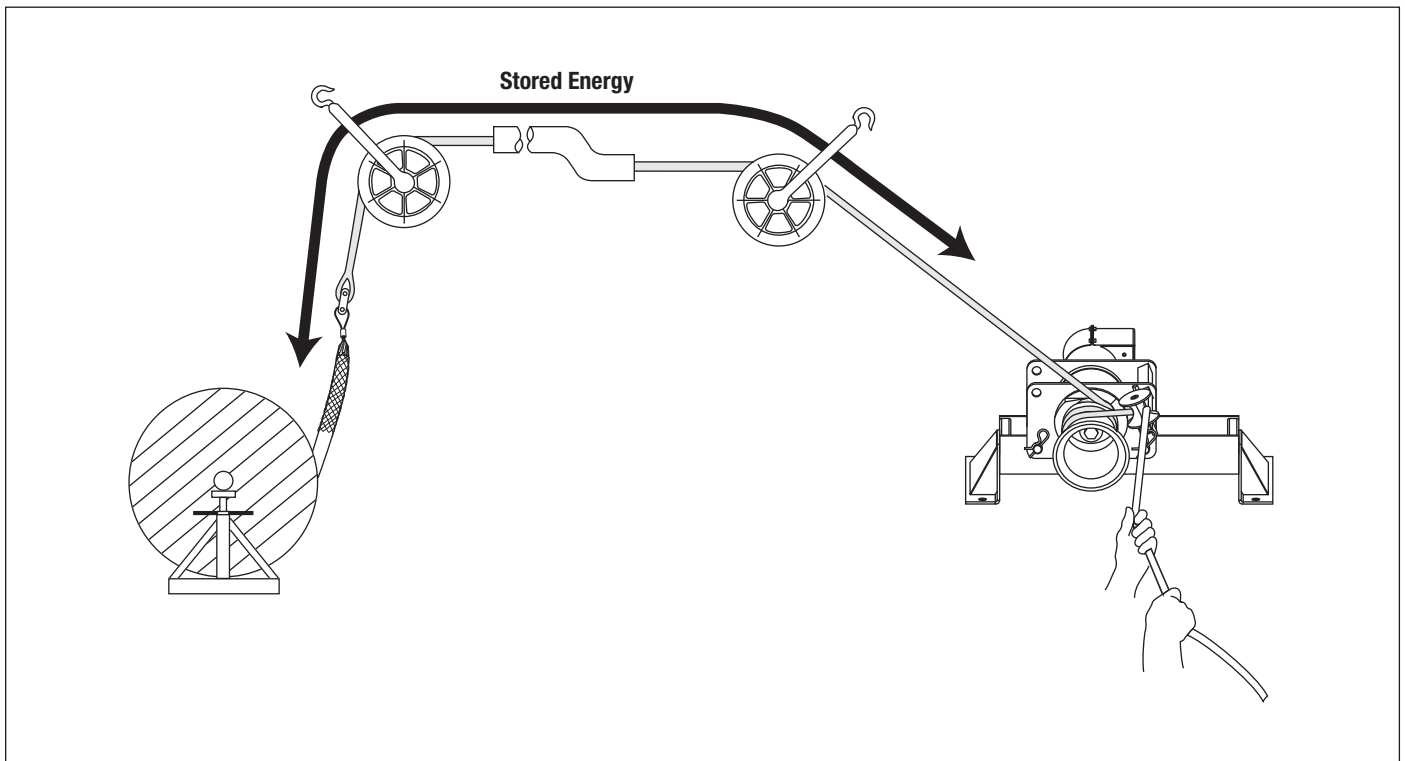

Cable Pulling Principles (cont'd)

Cable Pulling Forces (cont'd)

At the Connectors

The connectors will be subjected to the cable puller's maximum pulling force.

Several types of rope connectors—clevises, swivels, and rope-to-swivel connectors—are available. Follow the instructions provided with each to provide a good connection.

Two types of wire connectors—wire grips and pulling grips—are available. The wire grip uses a set screw to clamp onto the conductors of the cable. The pulling grip consists of a wire mesh basket that slides over the cable and grips the insulation.

When selecting a pulling grip, it is extremely important to select a grip of the correct (1) type, (2) size, and (3) maximum rated capacity.

1. Select the correct type based on the descriptions of each type in the Greenlee catalog.
2. Measure the circumference of the wire bundle. (To do this accurately, fasten a tie strap around the bundle. Cut off and discard the tail. Then cut the tie strap and measure its length.) Use the table provided to find the correct size.
3. See the maximum rated capacities in the Greenlee catalog.

A Typical Grip Setup—Clevis and Wire Grip

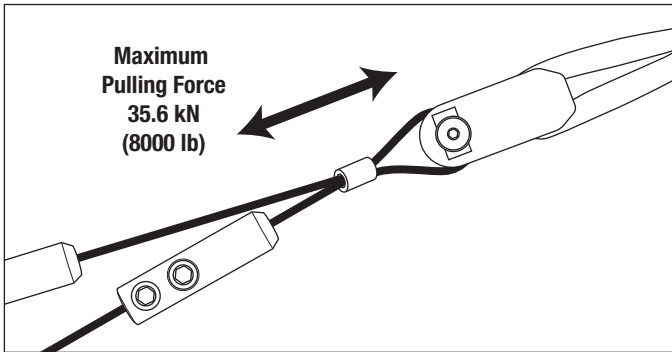

A Typical Grip Setup—Swivel and Pulling Grip

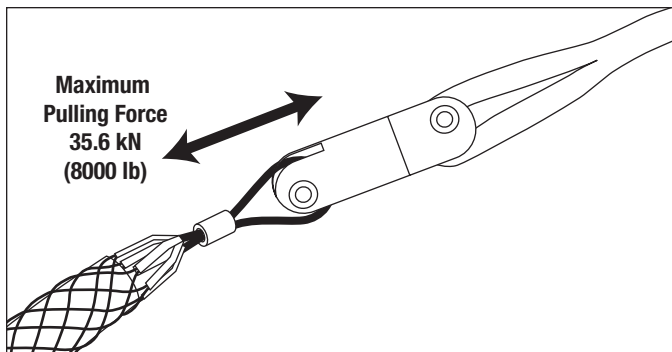

Pulling Grip Size Table

Circumference Range		Required Grip Diameter	
inches	mm	inches	mm
1.57 - 1.95	39.9 - 49.5	0.50 - 0.61	12.7 - 15.5
1.95 - 2.36	49.5 - 59.9	0.62 - 0.74	15.8 - 18.8
2.36 - 3.14	59.9 - 79.8	0.75 - 0.99	19.1 - 25.1
3.14 - 3.93	79.8 - 99.8	1.00 - 1.24	25.4 - 31.5
3.93 - 4.71	99.8 - 119.6	1.25 - 1.49	31.8 - 37.8
4.71 - 5.50	119.6 - 139.7	1.50 - 1.74	38.1 - 44.2
5.50 - 6.28	139.7 - 159.5	1.75 - 1.99	44.5 - 50.5
6.28 - 7.85	159.5 - 199.4	2.00 - 2.49	50.8 - 63.2
7.85 - 9.42	199.4 - 239.3	2.50 - 2.99	63.5 - 75.9
9.42 - 11.00	239.3 - 279.4	3.00 - 3.49	76.2 - 88.6
11.00 - 12.57	279.4 - 319.3	3.50 - 3.99	88.9 - 101.3
12.57 - 14.14	319.3 - 359.2	4.00 - 4.49	101.6 - 114.0
14.14 - 15.71	359.2 - 399.0	4.50 - 4.99	114.3 - 126.7



Cable Pulling Principles (cont'd)

Cable Pulling Forces (cont'd)

At the Sheaves

Sheaves are used to change the direction of the pull. A change in direction creates a new *resultant force* that may be greater than the cable puller's maximum pulling force. This new *resultant force* exerts itself on the sheaves, sheave anchoring system, and support structures illustrated.

The resultant amount of force depends on the angle of the change in direction. A brief table is provided here; For details on calculating the resultant force for any angle, see IM 1363 (99929988).

Resultant Force Table for the Ultra Tugger (35.6 kN or 8,000 lb Maximum Pulling Force)

Illustration	Angle of Change in Direction	Resultant Force in kN (lb)
	180°	0 (0)
	150°	18.5 (4160)
	135°	27.4 (6160)
	120°	35.6 (8000)
	90°	50.2 (11,300)
	60°	61.6 (13,800)
	45°	65.8 (14,800)
	30°	68.7 (15,400)
	0°	71.2 (16,000)

Typical Resultant Force at Sheave

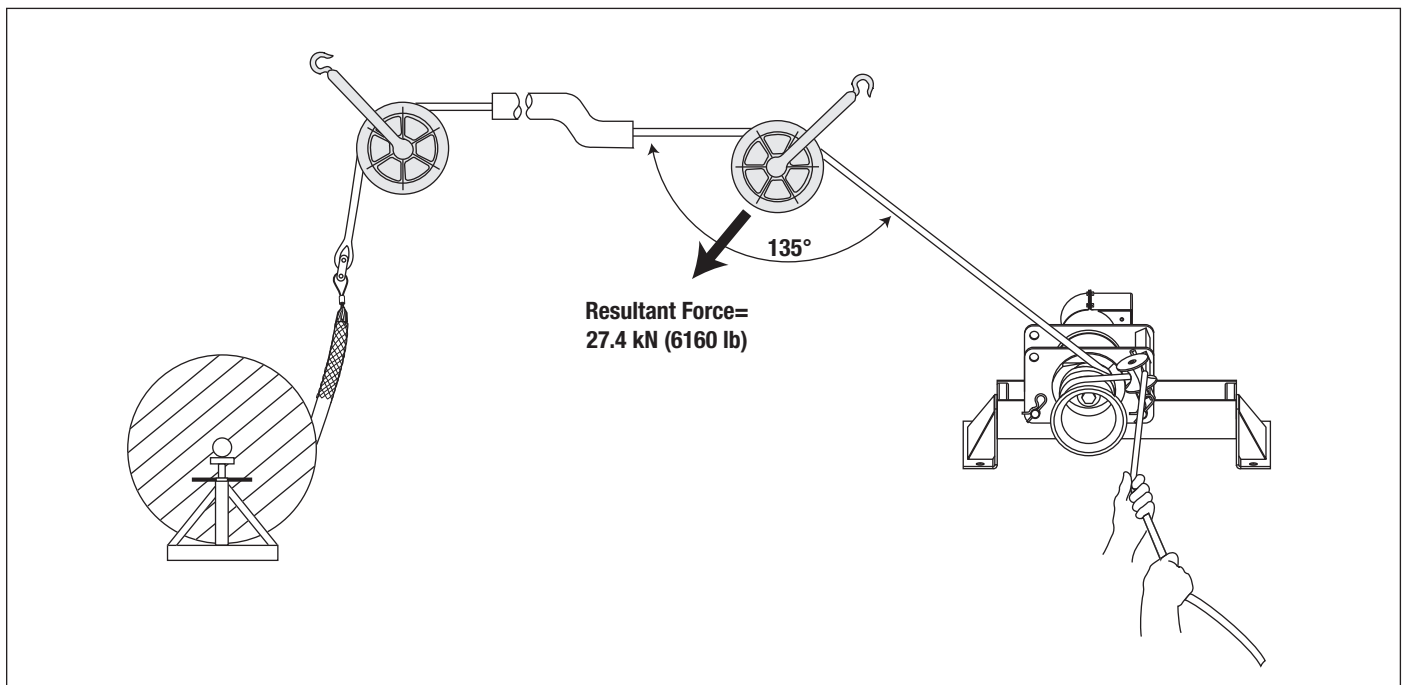



Cable Pulling Principles (cont'd)

Tailing the Rope

The rope must be pulled off of the capstan as the pull progresses. The rope that has left the capstan is the “tail.” The process of pulling the rope off of the capstan is called *tailing the rope*.

The resistance of the cable varies throughout the duration of the cable pull. Changes in resistance are due to characteristics of the rope, changes in conduit direction, and changes in the amount of friction. The “feel” of the rope provides this information about the pull. This is called *tactile feedback*. Adjust the tailing force as necessary to compensate for these changes.

Control of the Pull

Decreasing the tailing force will decrease the pulling force, until the rope slips on the capstan and the pull stops. This provides a high level of control over the progress of the cable pull.

Do not allow the rope to slip on the capstan for more than a few moments. If it becomes necessary to completely stop a pull, shut off the puller and maintain enough tailing force to hold cable in place. Tie the rope off to hold it in place.

Amount of Tailing Force

While the rope and cable are under tension, it is important to maintain the proper amount of tailing force.

Too little tailing force will allow the rope to slip on the capstan. This will build up excessive heat and accelerate rope wear, increasing the possibility of breaking the rope.

The proper amount of tailing force will stop the rope from slipping on the capstan and produce a sufficient amount of pulling force to pull in the rope and cable.

Too much tailing force is any amount more than is necessary to stop the rope from slipping on the capstan. Excessive tailing force will not increase the pulling force or pulling speed.

Number of Wraps of Rope Around the Capstan

An experienced operator should choose the number times the rope is wrapped around the capstan.

The proper number of wraps allows the operator to control the progress of the pull with a comfortable amount of effort.

Using *too few* wraps requires a large tailing force to accomplish the pull. Using too few wraps also makes the rope more likely to slip on the capstan. This builds up heat and accelerates rope wear.

Using *too many* wraps causes the rope to grab the capstan tighter. This accelerates rope wear, wastes power, and increases the possibility of a rope overlap. Using too many wraps also reduces tactile feedback, so you receive less information about the pull. You cannot quickly relax the tailing force when there are too many wraps.

If the rope becomes difficult to tail, add another wrap of rope. Turn off the puller and release all of the tension in the rope. Add a wrap and resume pulling. Be aware, however, that some pulls will require tension to hold the cables in place. In these cases, do not attempt to release all of the tension and add a wrap of rope. You will need to anticipate the number of wraps before starting the pull.

Preventing Rope Overlap

Do not allow the rope to become overlapped on the capstan during a pull.

A rope overlap will make it impossible to continue or back out of the pull.

If the rope becomes overlapped, you will lose control of the pull—the rope will advance with no tailing force and will not feed off of the capstan. The capstan will not allow you to reverse the direction of the rope, so you cannot back out of an overlap.

Set up the puller properly. The rope ramp and tapered capstan are intended to prevent rope overlap. See the instructions in the Operation section of this manual.

Every wrap of the rope must remain in direct contact with the capstan. During the pull, take great care to prevent the incoming rope from riding up and overlapping the next wrap. If an overlap begins to develop, immediately relax the tailing force on the rope so that the rope can feed back toward the conduit or tray. When the rope resumes its normal path, apply tailing force and continue the pull.

There is no suggested remedy for a rope overlap.

Do not allow the rope to overlap!



Cable Pulling Principles (cont'd)

Summary of Cable Pulling Principles

- A cable pulling system consists of many components that work together to accomplish a pull.
- The cable puller is rated by its maximum pulling force; every other component is rated by its maximum rated capacity. The maximum rated capacity of every component must meet or exceed the maximum pulling force of the cable puller.
- The cable puller must overcome two types of resistance: gravity and friction. The puller's capstan, the pulling rope, and the operator tailing the rope work together to produce pulling force.
- The cable puller exerts force on every component of the cable pulling system, including the anchoring systems and the support structures.
- Energy is stored in a rope when the load causes the rope to stretch. Failure of the rope or any other component can cause a sudden release of energy. Replace any rope that is worn or damaged.
- Carefully select the number of wraps of rope around the capstan before starting the pull.
- Control the pull by tailing the rope. Be familiar with the interaction of the rope and capstan.
- Do not allow a rope overlap to develop.

Planning the Pull

- Pull in a direction that will require the lowest amount of pulling force.
- Plan several shorter pulls rather than fewer longer pulls.
- Locate the puller as close to the end of the conduit as possible to minimize the amount of exposed rope under tension.
- Place each component so that the pulling forces are used effectively.
- Select an anchoring system: adapter sheaves, which are preferred, or the floor mount.
- Verify that each component has the proper load rating.
- Inspect the structural supports. Verify that they have enough strength to withstand the maximum forces that may be generated.

Typical Setups

Setups are shown without force gauge. Place the force gauge so the operator has an unobstructed view of the meter and quick access to its ON/OFF switch.

Chain Mount

Secured to Steel Conduit or Pipe

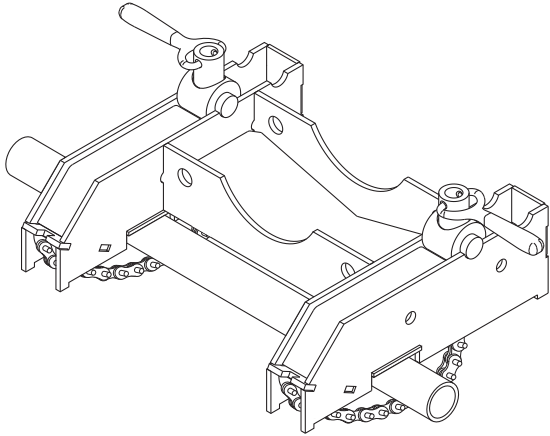

Floor Mount

Secured to a Concrete Floor

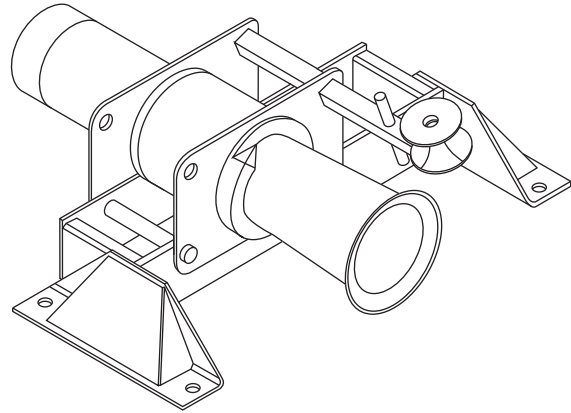

Locked and folded for transport

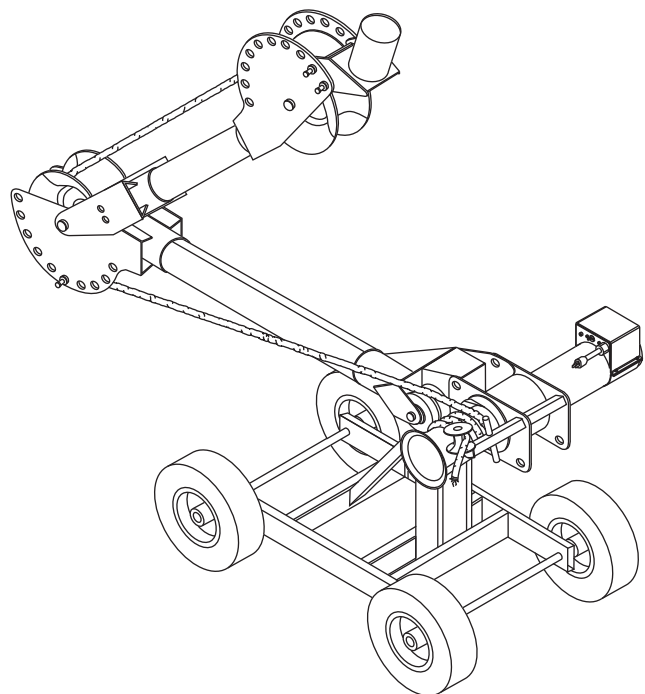



Typical Setups (cont'd)

Setups are shown without force gauge. Place the force gauge so the operator has an unobstructed view of the meter and quick access to its ON/OFF switch.

T-Stand

Pulling Horizontally Using One Boom Tube, Nose Unit and Slip-in Coupler

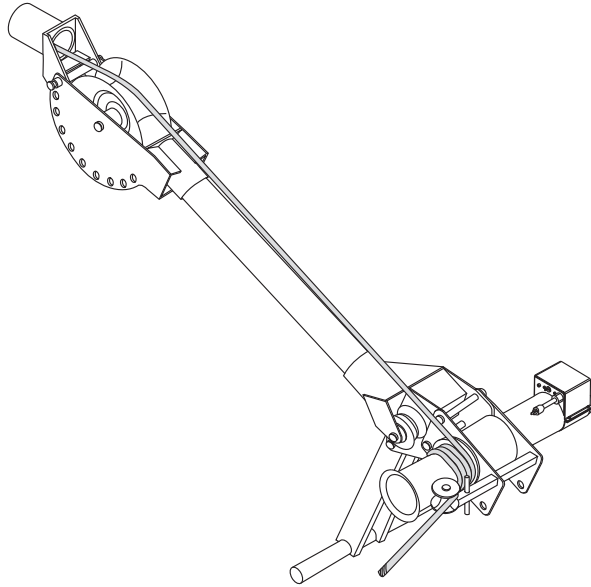

T-Stand

Pulling Horizontally Using Two Boom Tubes, Nose Unit, Elbow Unit and Slip-in Coupler

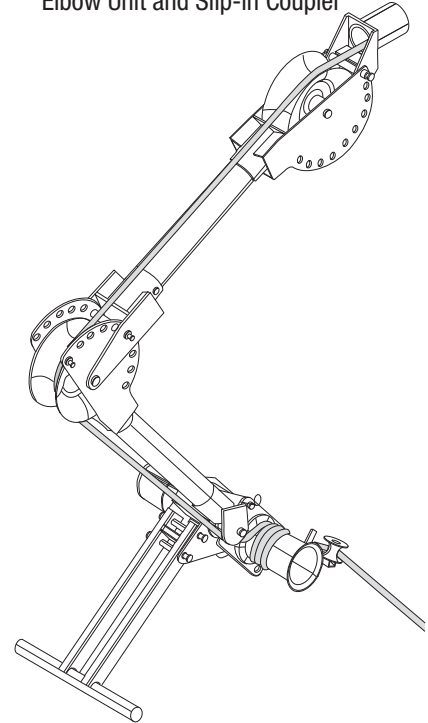

T-Stand

Pulling Up Using One Boom Tube, Nose Unit and Slip-in Coupler

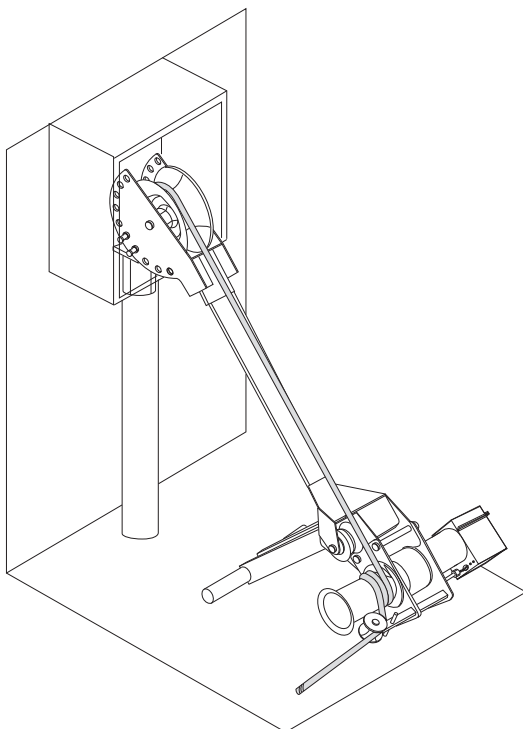

Down-pull using boom with threaded coupler

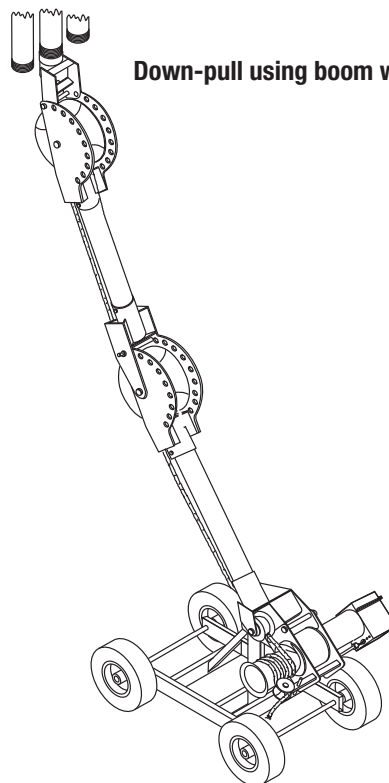

Typical Setups (cont'd)

Setups are shown without force gauge. Place the force gauge so the operator has an unobstructed view of the meter and quick access to its ON/OFF switch.

Wheeled Carriage

Pulling Up Using One Boom, Nose Unit and Slip-in Coupler

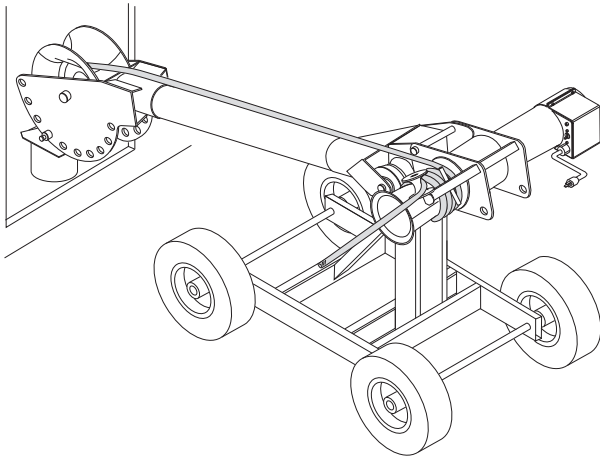

Wheeled Carriage

Pulling Horizontally in Manhole Using Two Booms, Nose Unit, Elbow Unit and Slip-in Coupler

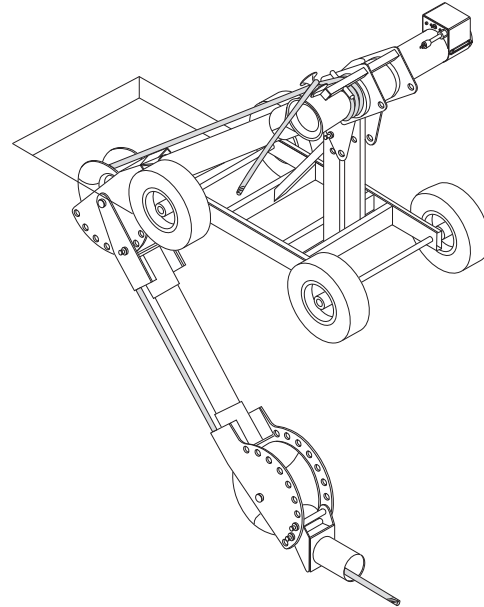

Wheeled Carriage

Pulling Up Using Two Booms, Nose Unit, Elbow Unit and Slip-in Coupler

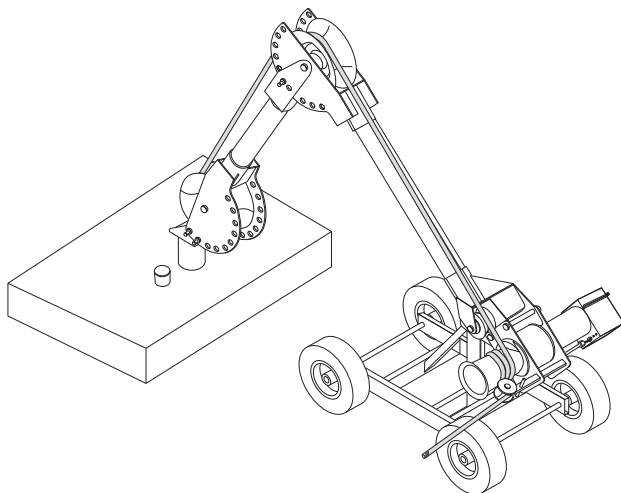

Wheeled Carriage

Pulling Horizontally in Manhole Using Two Booms, Nose Unit, Elbow Unit and Slip-in Coupler

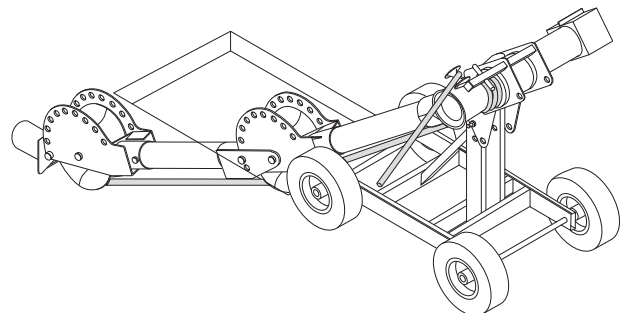







Setup—Pipe Adapter

As of 2006, the pipe adapter has been discontinued and replaced by the 11147 boom adapter. This information is reference for existing units.

Requires: Exposed metallic pull conduit of least 63.5 mm (2-1/2") diameter

	⚠ WARNING
	<p>Do not mount the pipe adapter to the following:</p> <ul style="list-style-type: none"> • steel conduit less than 65 mm (2-1/2") in diameter • PVC conduit of any size <p>These conduits will not support the loads imposed by the puller.</p> <p>Failure to observe this warning could result in severe injury or death.</p>

 	⚠ WARNING
	<p>When setting up the pipe adapter, do not use the vise chains on a structural support that is less than 51 mm (2") or more than 254 mm (10") wide. An oversized or under-sized structural support can allow the puller to slide or break loose and strike nearby personnel.</p> <p>Failure to observe this warning could result in severe injury or death.</p>

	⚠ WARNING
	<p>Mount pipe adapter only to conduit to be pulled from.</p> <p>Failure to observe this warning could result in severe injury or death.</p>

1. Remove the sheave from the frame.

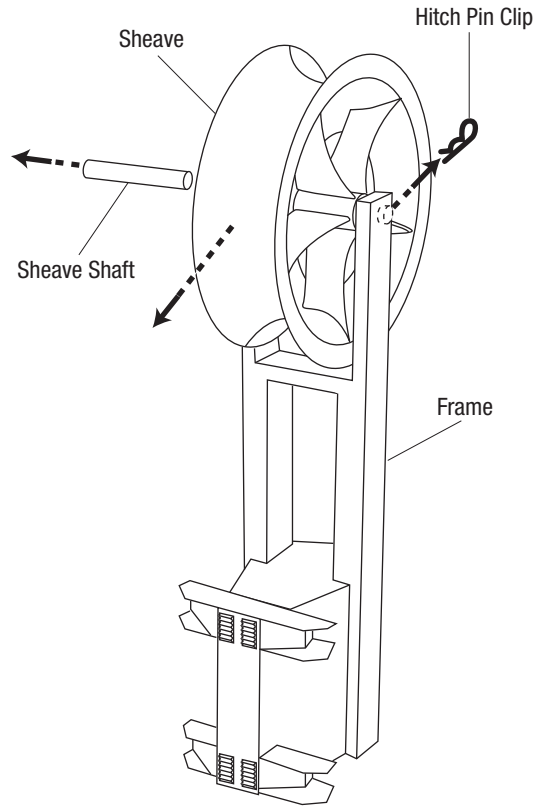

2. Position the frame against the conduit.

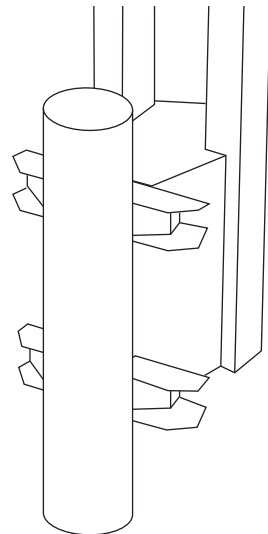



Setup—Pipe Adapter (cont'd)

⚠ WARNING

Install the vise chains properly.

- Follow the vise chain tightening instructions carefully. Improperly tightened chains can allow the puller to slide or break loose and strike nearby personnel.
- Do not allow the vise chains to bind at the corners when mounting the puller to a square or rectangular support. The vise chain must be uniformly tight at all points.

Failure to observe this warning could result in severe injury or death.

3. On each vise chain unit:
 - a. Rotate the vise chain handle counterclockwise to expose most of the threads. Leave only three or four threads engaged in the handle.
 - b. Insert the chain into the slot in the frame. Wrap the chain around the conduit, pipe sheave adapter, or structural element.
 - c. Set the positioner against the positioning blocks that protrude from the frame.
 - d. Pull the vise chain tight and insert the chain pins into the chain pockets, or recesses.
 - e. Turn the handle clockwise to slightly tighten the chain.

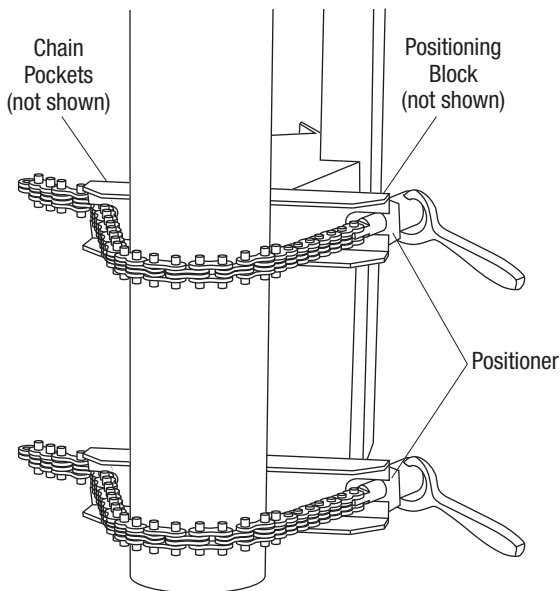

4. Rotate the vise chain handles, by hand, clockwise to tighten the chain. Do not use tools, extensions or “cheaters.”
5. Put the sheave back onto the frame. Install the pin and hitch pin clip.

Note: If the 18" sheave interferes with existing structures, install a 12" sheave (Greenlee 00843).

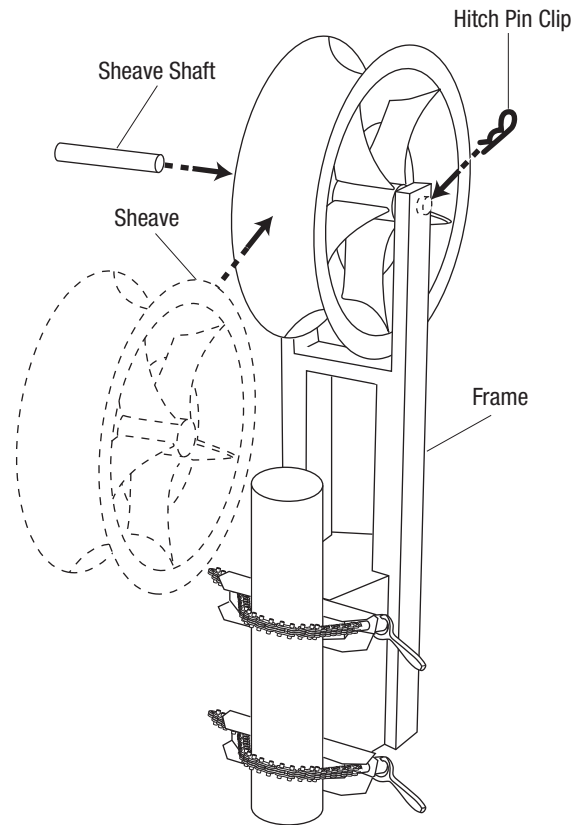

6. Align the puller so that the gearbox will fit into the cradle of the pipe adapter AND the puller mounting plates straddle the pipe adapter mounting plates.

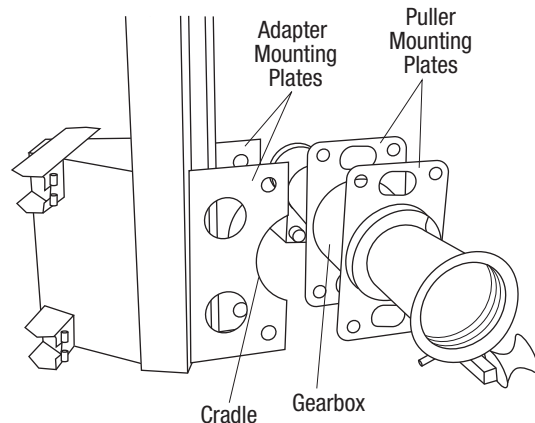



Setup—Pipe Adapter (cont'd)

7. Install two pins from the motor side. Secure the pins with two hitch pin clips.

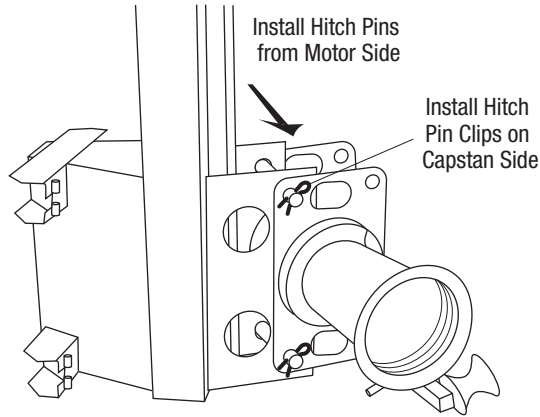

Setup—T-Stand

Requires: Adequate clearance. See Typical Setups Illustrated

1. Set the puller on the floor with the mounting holes upward.
2. Position the boom mount so that the puller gearbox will fit into the cradle of the boom mount and the puller mounting plates straddle the boom mount plates.

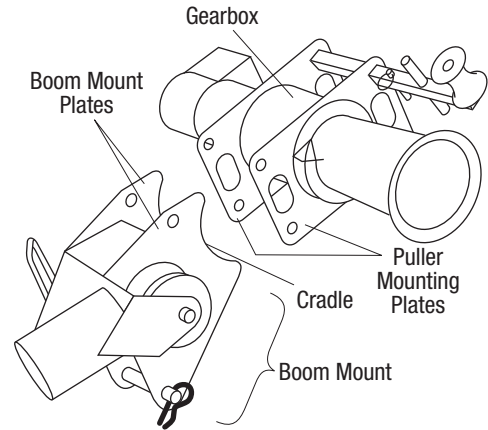

3. Mount the boom mount to the puller.
4. Install two pins from the motor side. Secure the pins with two hitch pin clips.

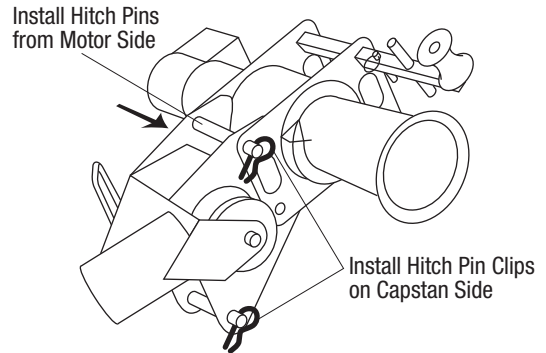

5. Align the two sets of holes in the T-stand with the two sets of holes in the boom mount.
6. Install two pins. Secure the pins with hitch pin clips.

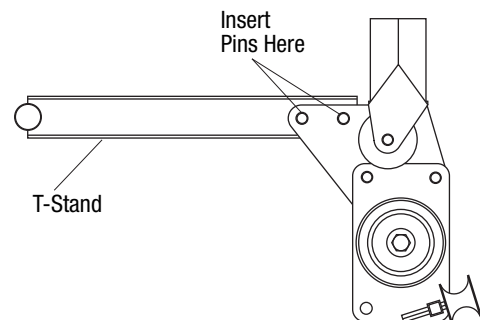

7. Continue with Setup: Mounting Components later in this manual.



Setup—Wheeled Carriage

Requires: Adequate clearance. See Typical Setups Illustrated

1. Mount the boom mount to the wheeled carriage. Align the boom mount holes with the top holes in the wheeled carriage, as illustrated. Install a pin through the boom mount and wheeled carriage. Secure the pin with a hitch pin clip.

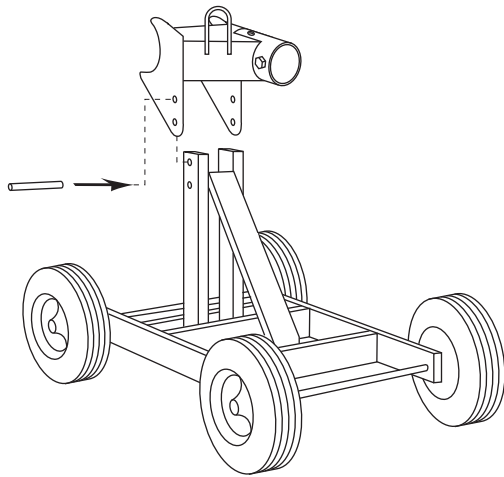

2. Position the puller's gearbox above the boom mount cradle. Align the puller so that the puller mounting plates straddle the boom mount plates. Lower the puller onto the boom mount. Install two pins from the motor side. Secure the pins with two hitch pin clips.

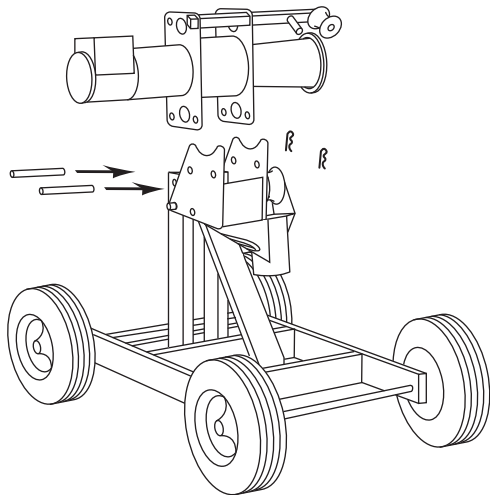

3. Check the right angle sheave support tube to be sure it is fastened with the pin.

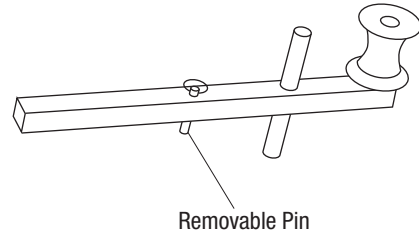

4. Rotate the puller and boom mount as shown. When the second hole in the boom mount is aligned with the second hole in the wheeled carriage, install a pin. Secure the pin with a hitch pin clip.

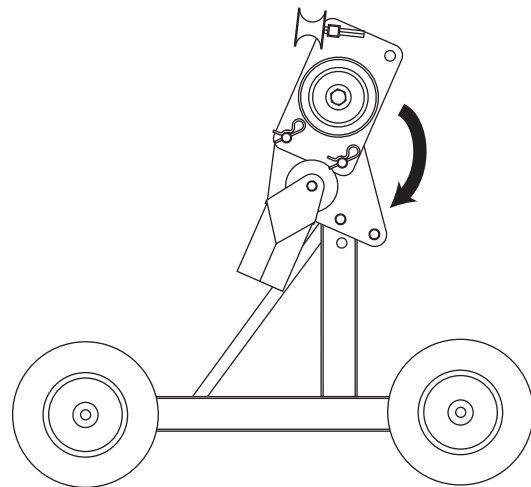



Setup—Mounting Components

Boom with Nose Unit

▲ WARNING

- Use only straight 3" diameter rigid steel conduit or Schedule 40 steel pipe for the boom tubes.
- Do not use boom tubes longer than 3 meters (10'). Longer booms may bend or break.

Failure to observe this warning could result in severe injury or death.

Use these boom tubes only:

- boom tubes supplied with the Ultra Tugger
- 3" rigid steel conduit (3 meters or 10 feet maximum)
- 3" Schedule 40 pipe (3 meters or 10 feet maximum)

1. Slide the boom tube into the boom mount until the tube bottoms out. Sight the tube through the sight hole to be sure the tube is fully inserted. Tighten the set screw.
2. Slide the nose unit onto the tube until the tube bottoms out. Sight the tube through the sight hole to be sure the tube is fully inserted. Tighten the set screw.

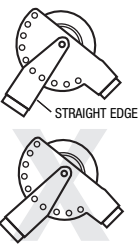

▲ WARNING

Set up the elbow unit as shown. Improper setup will cause the elbow unit to collapse.

Failure to observe this warning could result in severe injury or death.

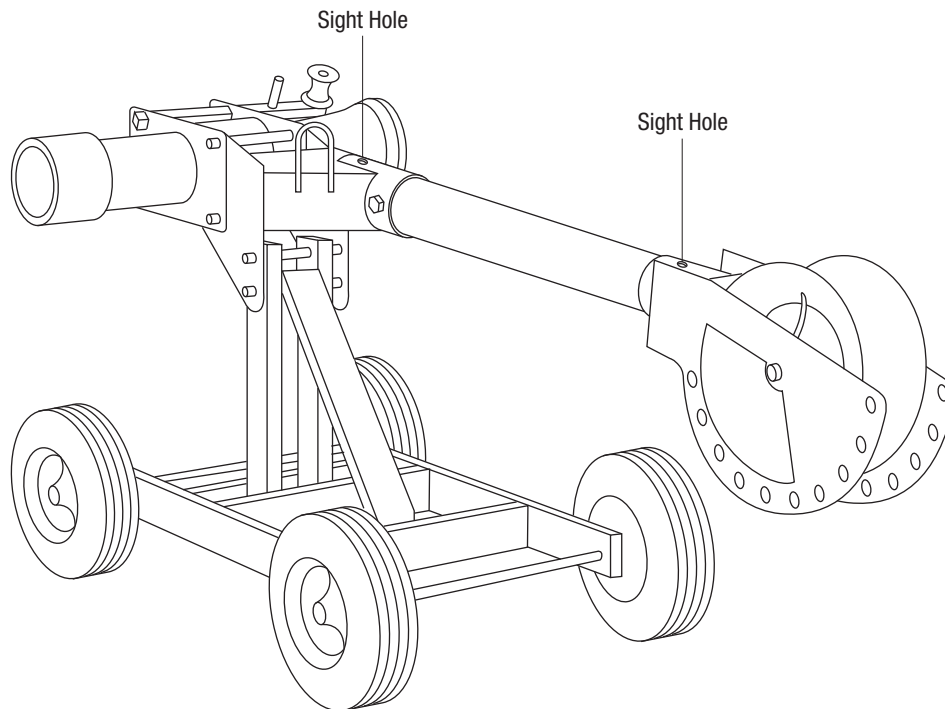



Setup—Mounting Components (cont'd)

Booms with Elbow Unit and Nose Unit

⚠ WARNING

- Use only straight 3" diameter rigid steel conduit or Schedule 40 steel pipe for the boom tubes.
- Do not use boom tubes longer than 3 meters (10'). Longer booms may bend or break.

Failure to observe this warning could result in severe injury or death.

⚠ WARNING

Set up the elbow unit as shown. Improper setup will cause the elbow unit to collapse.

Failure to observe this warning could result in severe injury or death.

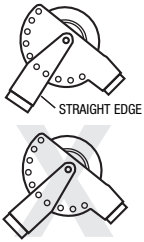

Use these boom tubes only:

- boom tubes supplied with the Ultra Tugger
- 3" rigid steel conduit (3 meters or 10 feet maximum)
- 3" Schedule 40 pipe (3 meters or 10 feet maximum)

1. Slide the boom tube into the boom mount until the tube bottoms out. Sight the tube through the sight hole to be sure the tube is fully inserted. Tighten the set screw.
2. Slide the elbow unit onto the tube until the tube bottoms out. Sight the tube through the sight hole to be sure the tube is fully inserted. Tighten the set screw.
3. Adjust the elbow to an appropriate angle and lock it in place with a pin. Secure the pin with a hitch pin clip.
4. Slide the boom tube into the elbow unit until the tube bottoms out. Sight the tube through the sight hole to be sure the tube is fully inserted. Tighten the set screw.
5. Slide the nose unit onto the tube until the tube bottoms out. Sight the tube through the sight hole to be sure the tube is fully inserted. Tighten the set screw.

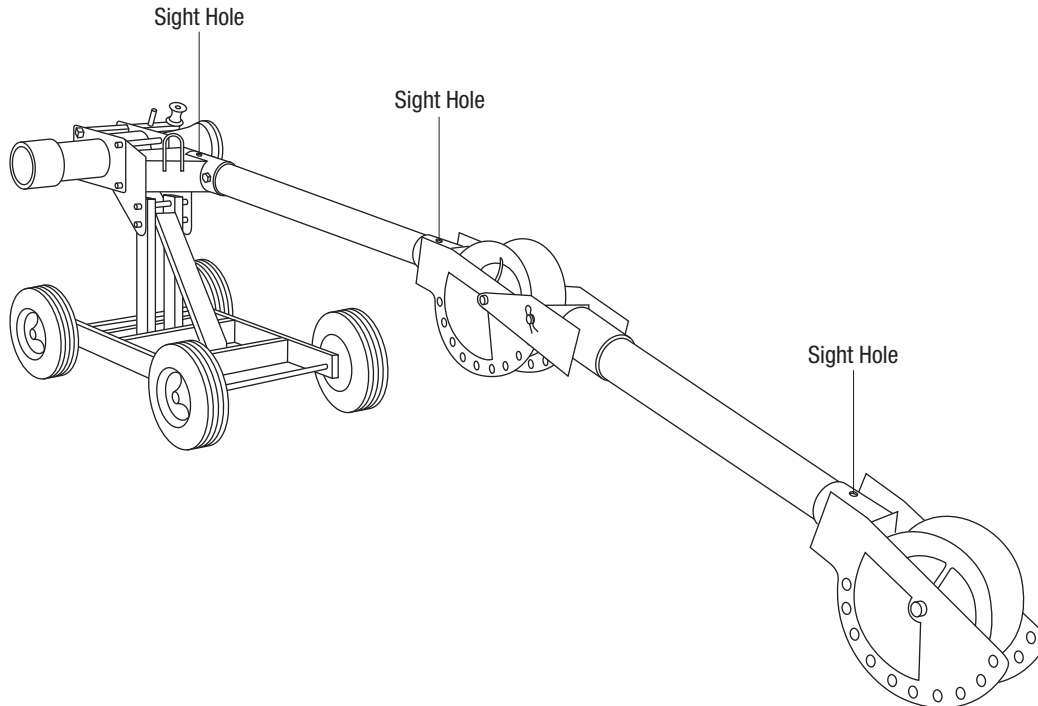



Setup—Versi-Boom™ System: Using Couplers

Choosing Couplers

There are three choices available for coupling the boom to the conduit. Use the chart below to determine which method of mounting to the conduit best suits your requirements:

Screw-On Couplers

Sizes: 2-1/2" – 4"

Advantages:

- Will support weight of boom when pulling from ceiling.
- No reduction of conduit opening.
- Only one pin required to attach to boom.

Disadvantages:

- Hardest to set up.
- Most loose pieces.
- Pull conduit must have exposed threads.
- Requires clearance around pull conduit to mount properly.

Slip-In Couplers

Sizes: 2-1/2" – 5"

Advantages:

- Easiest to set up.
- Only one part per size.
- Only one pin needed to attach to boom.

Disadvantages:

- Reduces conduit opening by 1/2".
- Can not be used if pulling down from ceiling.
- Requires clearance around the conduit to seat properly.

Straddling Conduit Using Slip-In Couplers

Sizes: Up to 4"

Advantages:

- Easy to set up.
- Only one part per size.
- Can be used for sizes below 2-1/2".
- Can clear obstructions around conduit (other conduit, pull box, door edges, etc.).

Disadvantages:

- Will only fit over the threads of 4" and won't fit over 5" conduit.
- Must use external support to hold weight of boom if pulling from ceiling.
- Must be seated against support structure capable of supporting 8000 pounds.
- Requires two pins to attach to boom.



Setup—Versi-Boom™ System: Using Couplers (cont'd)

Screw-On Couplers and Coupler Adapters

1. Choose the coupler that best fits the conduit.
2. Screw it onto the conduit until tight and then back it off until the flat plate faces the puller.
3. Slide the coupler adapter onto the coupler. Make sure the flat plate is trapped by the keepers on the adapter.
4. Lock in place with the locking screws.

⚠ WARNING
Check the condition of pull conduit threads. Pull conduit must have a minimum of 3 full threads in good condition to support the pulling loads.

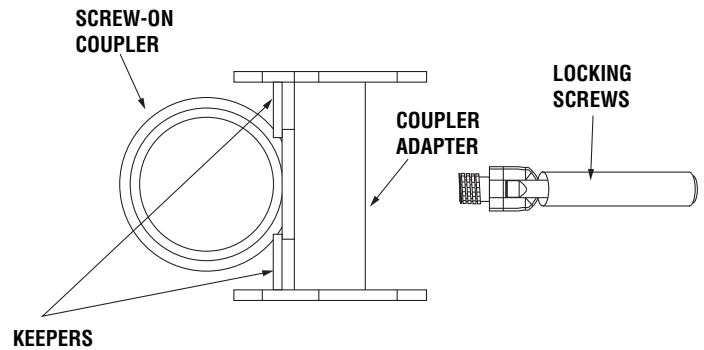
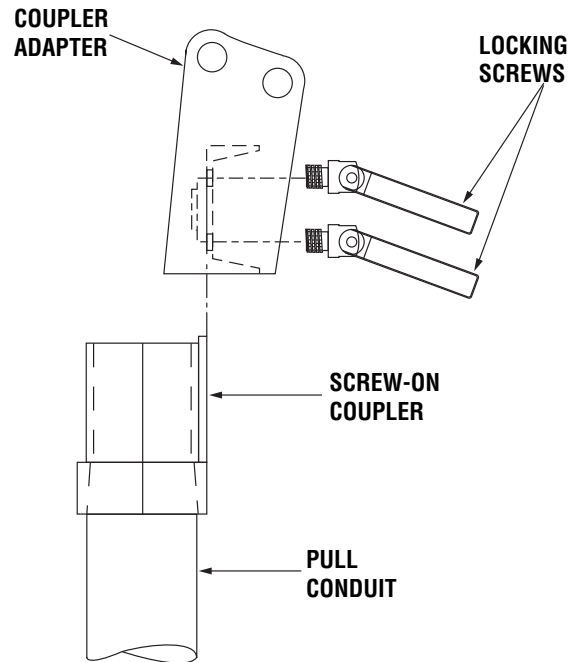



Setup—Versi-Boom™ System: Using Couplers (cont'd)

Slip-in Couplers

Requires: One pin to connect to Nose Unit

1. Select the coupler that best fits the conduit.
2. Slide the coupler into the conduit until the coupler seats on the end of the conduit.

Note: If the coupler doesn't seat on the conduit, see Straddling the Conduit with a Slip-In Coupler.

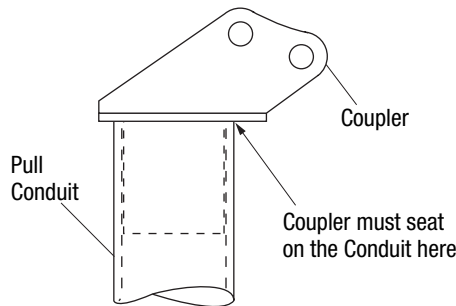

3. Slide the nose unit over the coupler. Align any set of holes and insert one pin. Secure the pin with a hitch pin clip.

Note: If possible, add a second pin and hitch pin clip.

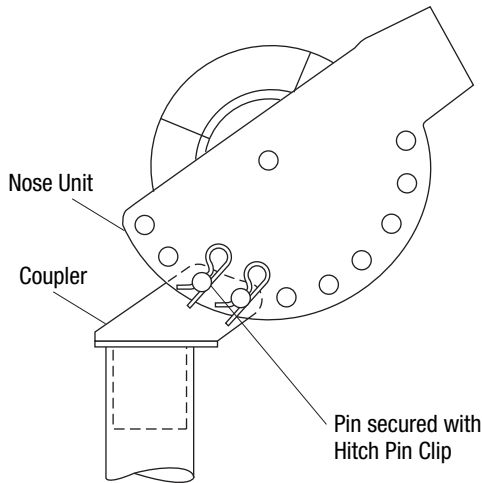

Straddling the Conduit with Slip-in Coupler

Requires: Two pins to connect to Nose Unit

1. Select a coupler at least 25 mm (1") larger than the conduit.
2. Place the coupler over the conduit.

Note: Do not use this method if the coupler does not seat on a support structure that can support 35.6 kN (8000 lb) of force.

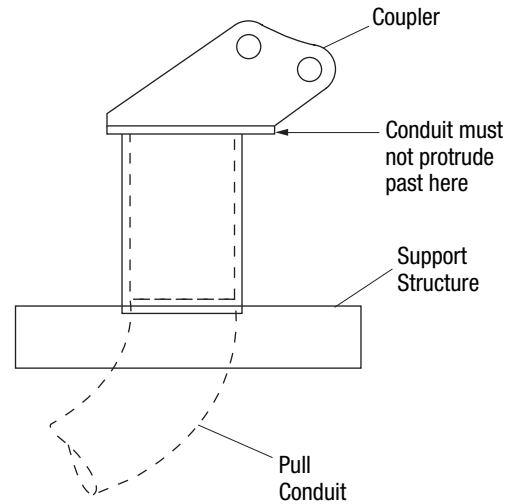

3. Slide the nose unit over the coupler. Align any two sets of holes and insert two pins. Secure the pins with hitch pin clips.

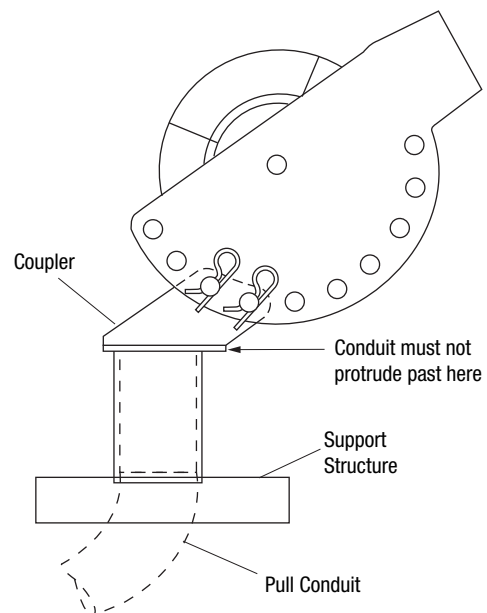

Setup—Versi-Boom™ System: Assembling Boom Components

Using Double Boom, Elbow and Nose Units:

Use only Greenlee supplied boom tubes, 3" rigid steel conduit or 3" schedule 40 steel pipe (less than 10') with the Versi-Boom™ systems.

1. Place boom tube into receptacle of boom mount. Boom tube must slide completely into boom mount. Make sure the boom tube can be seen through the sight holes.
2. Tighten the set screws.
3. Adjust elbow to an appropriate angle and lock in place with long pin and hitch clip.
4. Slide either end of elbow over boom tube. Boom tube must slide completely into elbow unit. Make sure the boom tube can be seen through the sight holes.
5. Tighten set screws.
6. Slide second boom tube into elbow unit. Boom tube must slide completely into elbow unit. Make sure the boom tube can be seen through the sight holes.
7. Tighten set screws.
8. Slip nose unit onto boom tube. Nose unit should fit completely over the boom tube. Make sure the boom tube can be seen in the sight holes.
9. Tighten set screws.

Note: The nose unit of the boom should attach to the coupler so that the cable being pulled will pass directly onto the sheave without dragging over the edges of the coupler. The boom nose unit has been designed so that the sheave is in perfect alignment with the conduit whenever any two sets of holes from the nose unit and coupler line up.

10. Raise the boom assembly and slide the nose unit over the coupler (see Using Couplers). BOTH mounting plates of the nose unit should be OUTSIDE the mounting plates of the coupler.
11. Find two sets of holes on the nose unit that most closely line up with coupler holes.
12. Insert short pin through holes closest to the conduit. Lock in place with a hitch clip. Use two pins whenever possible.

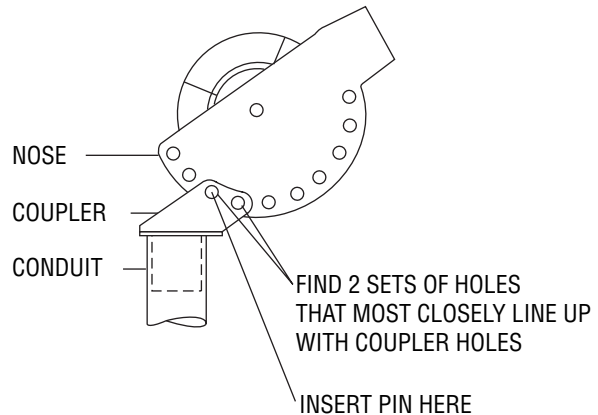

Note: If a slip-in coupler is being used to straddle the conduit (see Using Couplers), two pins MUST be used to connect nose unit and coupler. Some extra adjustment may be required to install second pin.

⚠ WARNING

Two pins must be used if coupler is not fully inserted or attached to conduit. Nose unit may collapse, causing serious injury or death.



⚠ WARNING

Shear Point:

Never put fingers through holes in boom components. Pivoting of mating parts may cut off fingers. Always keep elbow unit locked with pivot pin except while adjusting.

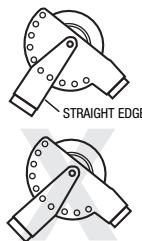

⚠ WARNING

Proper assembly of elbow unit must be maintained. If elbow is disassembled, it must be reassembled with the proper orientation as shown. Improper assembly could result in collapse of boom.

Setup—Versi-Boom™ System: Special Situations

Down Pulls:

The idler wheel on the boom mount must be used during down pulls. In down pulls the pull rope will pass underneath the boom nose sheave. The idler wheel must be used as shown to get the rope from underneath the boom to the top of the capstan.

Down Pulls/Elbow Unit:

If the pull rope passes OVER the nose unit sheave then it must pass OVER the elbow unit sheave. The idler wheel is not used.

If the pull rope passes UNDER the nose unit sheave then it must pass UNDER the elbow unit sheave. The rope must then pass under the idler wheel and on to the capstan. (See Down Pull with Threaded Coupler, page 16.)

Rotating Boom Nose and Elbow:

Keep nose, elbow and puller in line whenever possible. Do not use the nose or elbow at an angles which make the rope twist or wrap around the boom. Rope wear may occur.

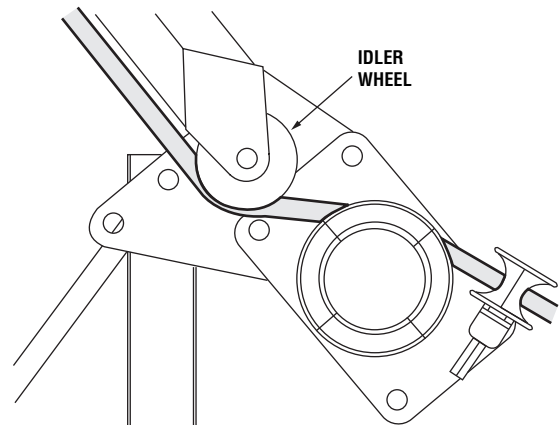

Idler Wheel

⚠ CAUTION

Couplers may break if the weight of the puller is not properly supported. Do not allow the puller and boom to hang from slip-in or screw-in couplers. Damage to the coupler and rope may result. Use the wheeled carriage or T-stand to support the weight of the puller at the motor and capstan.

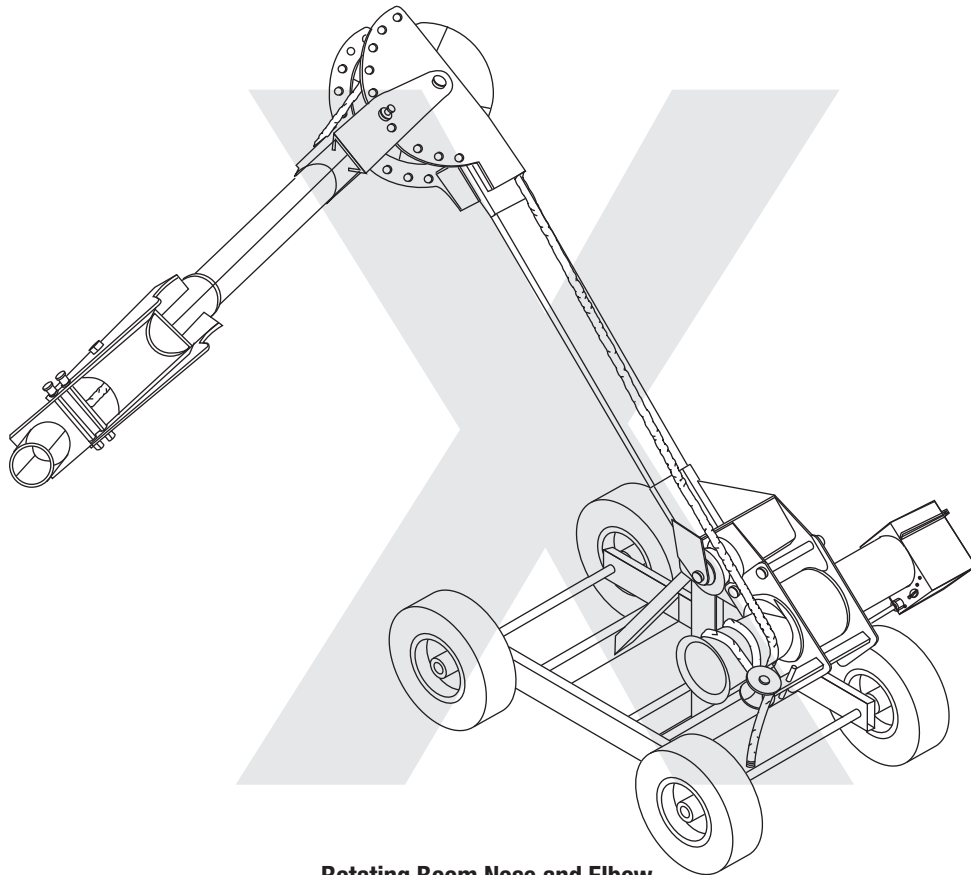

Rotating Boom Nose and Elbow

Setup—Versi-Boom™ System: Moving the Wheeled Carriage

Moving the Puller and Boom:

Lock the boom mount to the wheeled carriage before moving. Align both sets of boom mount holes with both sets of holes on carriage. Insert short pins and lock with hitch clips. If elbow is used, fold it back against top as shown.

Note: If boom sections longer than the stock 3' and 4' boom tubes are used, the unit may not balance on all four wheels. Break down long boom sections before moving.

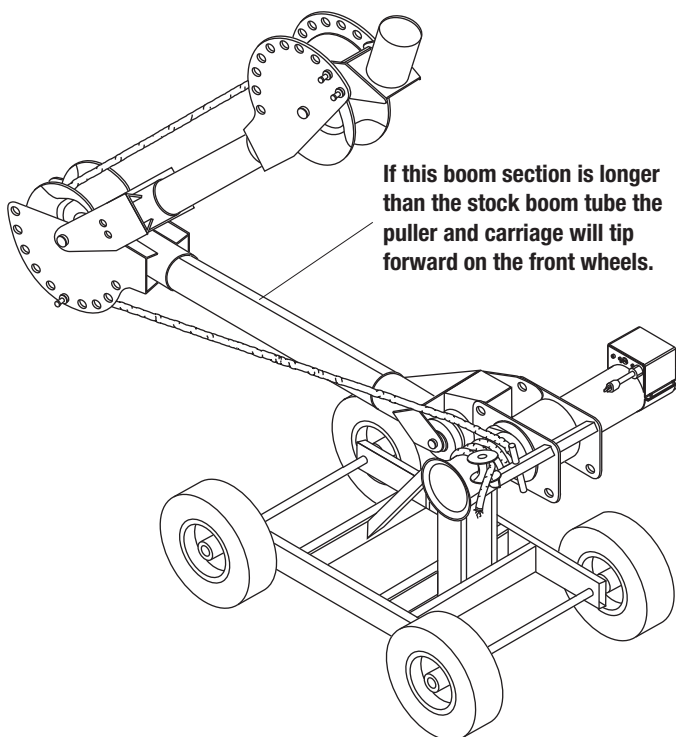
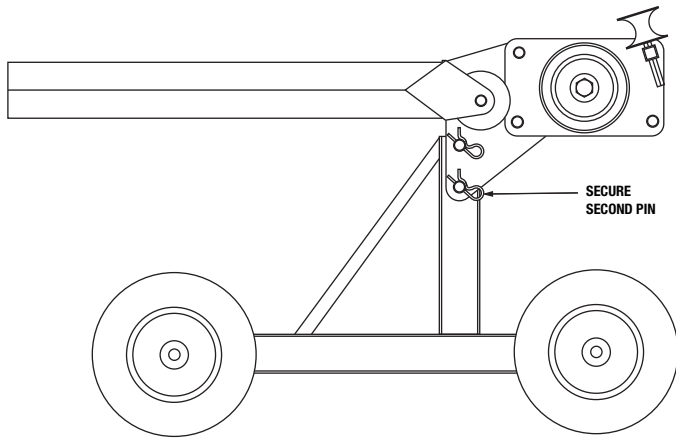

⚠ WARNING

Wheeled carriage with boom is heavy and may be unstable over some terrain.

- Keep personnel out of path of transport.
- Evaluate the terrain over which the carriage is to move. If in doubt, obtain additional help and move unit cautiously.

⚠ WARNING

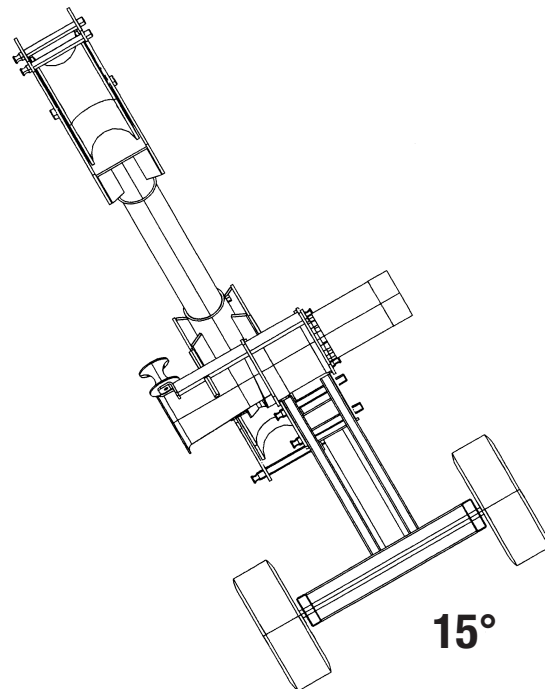

Do not transport over inclines greater than 15°.

Do not transport with boom tubes longer than the stock 3' and 4' lengths.

Improper transport may result in tipping causing serious injury.





Setup—Chain Mount

Requires: Exposed metallic conduit with the following characteristics:

- 63.5 – 254 mm (2-1/2" – 10") in diameter
- capable of withstanding at least 35.6 kN (8000 lb) of force

	⚠ WARNING
	<p>Do not mount the pipe adapter to the following:</p> <ul style="list-style-type: none"> • steel conduit less than 63.5 mm (2-1/2") in diameter • PVC conduit of any size <p>These conduits will not support the loads imposed by the puller.</p> <p>Failure to observe this warning could result in severe injury or death.</p>

 	⚠ WARNING
	<p>When setting up the pipe adapter, do not use the vise chains on a structural support that is less than 51 mm (2") or more than 254 mm (10") wide. An oversized or undersized structural support can allow the puller to slide or break loose and strike nearby personnel.</p> <p>Failure to observe this warning could result in severe injury or death.</p>

⚠ WARNING
<p>Install the vise chains properly.</p> <ul style="list-style-type: none"> • Follow the vise chain tightening instructions carefully. Improperly tightened chains can allow the puller to slide or break loose and strike nearby personnel. • Do not allow the vise chains to bind at the corners when mounting the puller to a square or rectangular support. The vise chain must be uniformly tight at all points. <p>Failure to observe this warning could result in severe injury or death.</p>

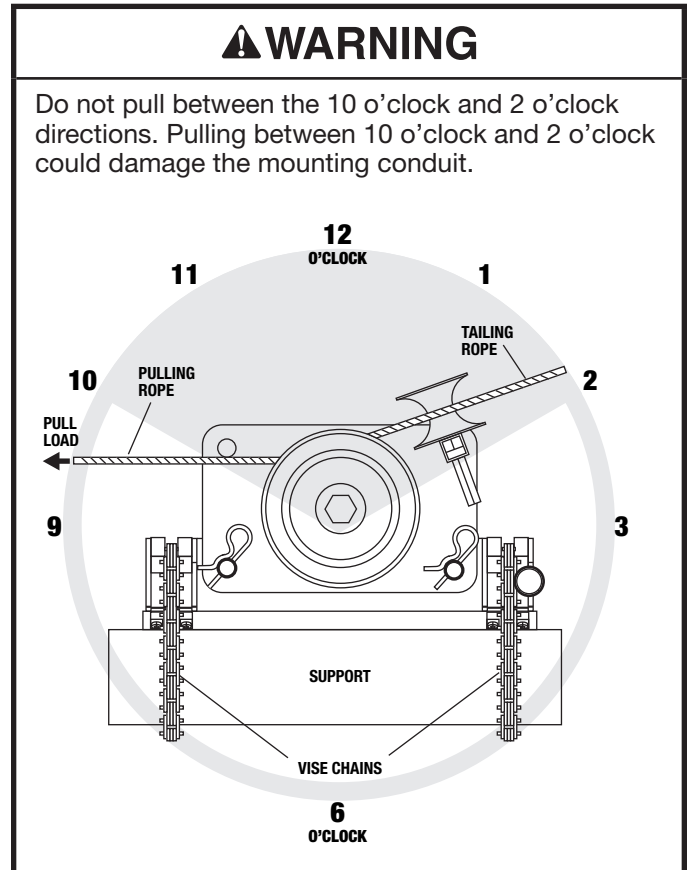



Setup—Chain Mount (cont'd)

1. On each vise chain unit:
 - a. Rotate the vise chain handle counterclockwise to expose most of the threads. Leave only three or four threads engaged in the handle.
 - b. Wrap the chain around the conduit.

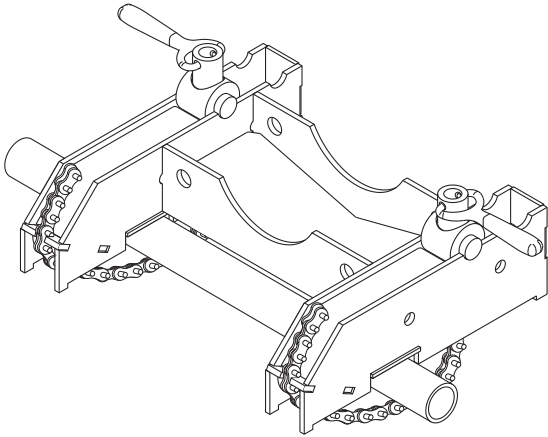

- c. Pull the vise chain tight and insert the chain pins into the chain pockets, or recesses.
 - d. Turn the handle clockwise to slightly tighten the chain.
2. Set the puller into the cradle of the chain mount.
3. Install two pins from the motor side. Secure the pins with two hitch pin clips.

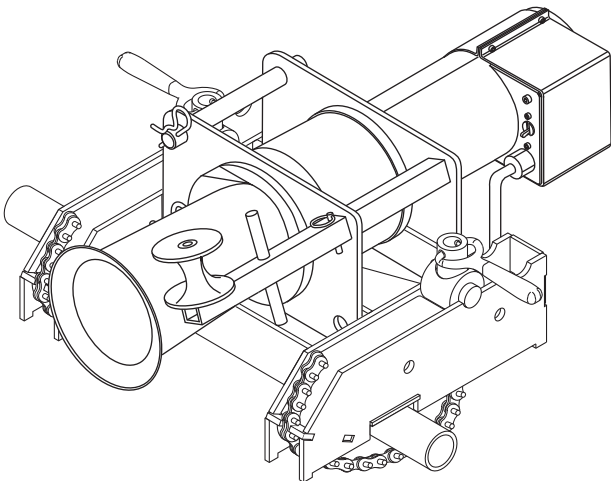

Setup—Floor Mount

Requires: A concrete floor with the following characteristics:

- fully cured structural-type concrete
- minimum compressive strength of 211 kg/cm² (3000 psi)
- free of cracks, crumbling, or patchwork

⚠ WARNING

Follow all floor mounting instructions carefully.

- An improperly attached floor mount can come loose and strike nearby personnel.
- Do not attach the floor mount to masonry, brick, or cinder block. These materials will not hold the anchors securely.

Failure to observe this warning could result in severe injury or death.

1. Determine the best position for locating the floor mount. Locate the floor mount:
 - on a flat section
 - at least 152 mm (6") from edge of concrete
 - as close to the conduit as possible to reduce the amount of exposed rope under tension
 - so that the pull rope will approach the puller's capstan at a 90° (± 5°) angle.

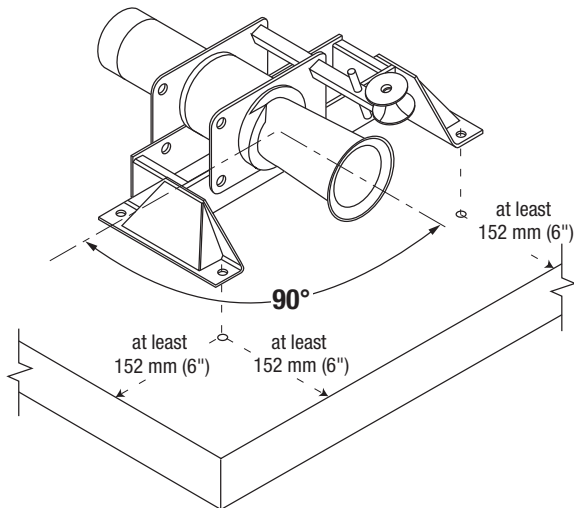

2. Set the floor mount in the desired location. Use the floor mount as a template to drill four 5/8" holes at least 152 mm (6") deep.

Note: Use a 5/8" carbide-tipped masonry bit manufactured in accordance with ANSI standard B94.12-77.

3. Vacuum the debris from the holes.

Installation

Greenlee recommends using Greenlee 35607 Wedge Anchors. If another type of anchor is used, they must have an ICBO (International Conference of Building Officials) allowable tension and shear rating of 10.7 kN (2400 lb) in 211 kg/cm² (3000 psi) concrete.

1. Assemble the nut and washer to the anchor so the top of the nut is flush with the top of the anchor, as shown.

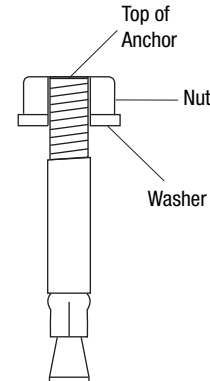

2. Insert the four anchors through the floor mount and into the holes in the floor.
3. Hammer the anchors in until the washer is in firm contact with the floor mount.

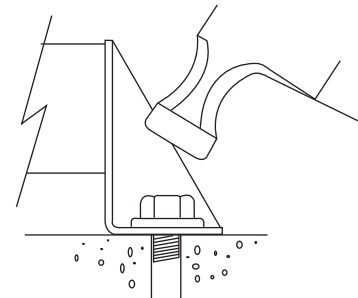

4. Expand the anchors by torquing the nuts to 122 to 128 Newton-meters (90 to 95 ft-lb).

⚠ WARNING

If any of the four anchors spin before the minimum torque is achieved, abandon the location and start elsewhere. An improperly installed anchor can allow the puller to break loose.

Failure to observe this warning could result in severe injury or death.

5. Have the installation checked by a qualified inspector.

Operation

1. Fish the rope through the conduit.
2. Set up the cable puller. See Typical Setups illustrations and instructions in this manual.

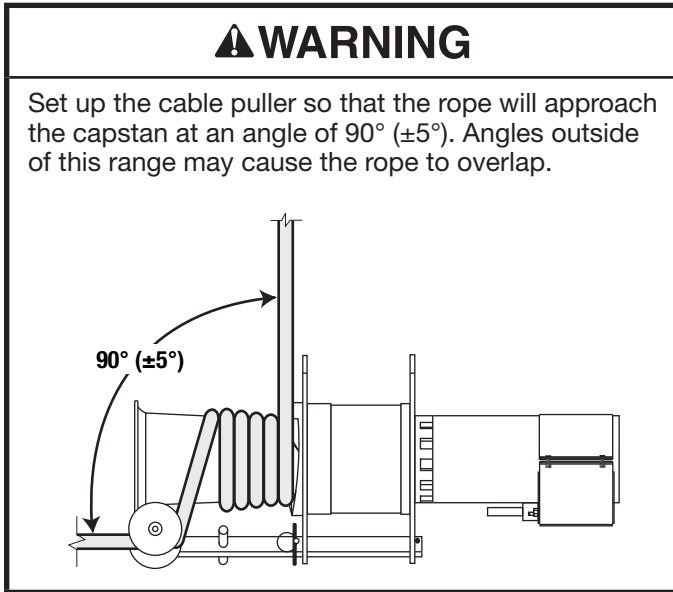

3. Set the rope ramp as follows:

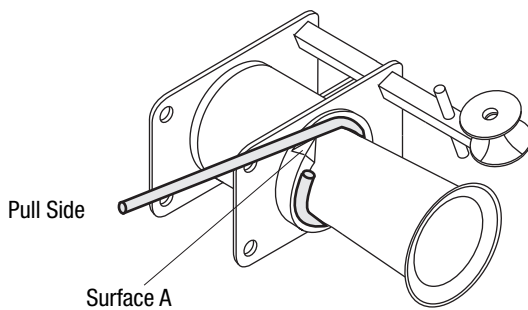

- a. Wind the rope several times around the capstan.
- b. Pull the ramp away from the mounting plate and rotate it until Surface A contacts the rope.
- c. Push the ramp toward the mounting plate and rotate it counterclockwise until it locks into place.

4. Check the ON/OFF switch on the puller to be sure it is OFF. Plug the puller into the receptacle of the standard force gauge.
5. Connect the force gauge to an appropriate power supply (see Grounding Instructions in this manual).

Note: If using an extension cord, it must be rated for 20 amps. Use the shortest cord possible. Longer cords reduce puller speed.

6. Position the force gauge so that it can be monitored by the puller operator.

Color Band on Meter	Pounds of Pulling Force	Alarm	Duty Cycle (in minutes)
Green	0 - 6500	OFF	continuous
Yellow	6500 - 8000	ON	15 ON / 15 OFF
Red	over 8000	ON	puller will stop

7. Turn the circuit breaker in the force gauge ON.
8. Grasp the tailing end of the rope. Apply a slight amount of tailing force.
9. Turn the puller ON.
10. Tail the rope, allowing the spent rope to accumulate on the floor between the operator and the puller.
11. When the pull is complete, turn the puller OFF. Tie off the rope and anchor the cable.

Removing Cable

Removing old cable involves the same principles as installing new cable. However, there are some important differences.

Pulling Force

It is difficult to predict the amount of pulling force necessary to remove an old cable. The cable may be damaged, and it may break with an unexpectedly low pulling force.

The required pulling forces may be very high:

- The cable has probably “taken a set.” Unlike the new cable on a reel, cable in conduit has probably been in the conduit for years, or perhaps decades. The cable will resist bending and straightening as it is pulled through the conduit.
- The pulling lubricant has probably hardened, increasing pulling resistance.
- The insulation may be damaged and the cable may be corroded.
- Dirt or other foreign matter may have entered the conduit and may have cemented the cable in place.

Using a Force Gauge

When pulling old cable out of a conduit, the pulling force will be highest when *starting* the pull. Select a cable puller and pulling components to meet or exceed the estimated amount of pulling force necessary to remove the old cable. Because breaking the cable free will require the largest amount of pulling force, it is necessary to use a force gauge to prevent overloading the system components. Select either the 01069 Standard Force Gauge or the 00967 Deluxe Force Gauge.

Carefully monitor the pulling force at the force gauge; if the puller is not able to begin the pull, shut off the puller and disassemble the setup. Start over with a puller and components of a higher force rating.

Puller Placement

Pulling out old cable is generally accomplished with the puller located some distance away from the end of the conduit. This allows the pulling crew to pull out a long section of cable before turning off the puller, cutting off the cable, and reattaching the grip(s). Mounting the cable puller a distance away from the end of the conduit increases the amount of exposed rope, which greatly increases the amount of violent whipping action which would occur if the rope were to break.

To isolate the operator from the rope path:

- Locate the puller so that you will stand behind an obstruction, such as a wall. Set up the puller so that you will be able to maintain control of the pull. You need a clear view of the rope as it feeds onto the capstan, including several feet of the rope in front of the capstan. You must be able to turn off the puller before the pulling grip, connector, or swivel contacts the capstan.
- Use an additional pulling sheave (if necessary) to change the direction of the tailing rope. Anchor the sheave so that you are close enough to maintain control of the pull. You need a clear view of the rope as it feeds onto the capstan, including several feet of the rope in front of the capstan. You must be able to turn off the puller before the pulling grip, connector, or swivel contacts the capstan.
Note: Use the additional pulling sheave to change the direction of the tailing rope (after the rope leaves the capstan). Do not change the direction of the pulling rope.
- Use a longer tailing rope than usual and stand away from the puller. Stand as far from the puller as possible, while maintaining control of the pull. You need a clear view of the rope as it feeds onto the capstan, including several feet of the rope in front of the capstan. You must be able to turn off the puller before the pulling grip, connector, or swivel contacts the capstan.



Maintenance

IMPORTANT

Maintenance should be performed by authorized personnel only.

General Maintenance Notes

- Replace any part that is broken, cracked or worn.
- Replace any bearings that don't turn freely.
- Clean all mating surfaces before assembly.
- Replace gearbox grease with Sentinel SL-WPG or equivalent.

Specific Service Notes

- Average brush life for commutator brushes is about 100 hours. Replace brushes if they are shorter than 9.5 mm (3/8").
- Replace rope ramp if it is grooved more than 6.5 mm (1/4").
- Replace the capstan if it is grooved more than 0.15 mm (1/16").
- The puller should not require any lubrication during its normal service life.

Switchbox Removal

1. Remove the four hex head cap screws (12) and nuts (13) that secure the clamp (6) to the switchbox (5).
2. Remove the clamp and pull switchbox from the motor.
3. Disconnect the white and black motor leads from the rectifier.
4. Unscrew the green ground wire from the motor.
5. Remove switchbox.

Switchbox Assembly Notes

1. If replacing the rectifier, use a heat conductive paste between the rectifier and the switchbox.
2. Connect the white motor lead to the positive (+) terminal on the rectifier. Connect the black motor lead to the negative (-) terminal.

IMPORTANT

The first reduction hub will be damaged if the leads are reversed.

3. Secure motor leads to motor using tie-wraps. Make sure the wires will not contact the commutator.
4. Position the switchbox and clamp so that the vent holes are towards the rear of the motor.

Motor Removal

See Exploded View – Motor.

1. Remove switchbox.
2. Push in and pull out the tab to release the commutator brush springs.
3. Use a 7/16" socket to remove nuts and washers at rear of motor.
4. Pull the motor off of the tail housing (3).
5. Pull off commutator brush assembly (1, 2 and 4).
6. Pull off magnet housing (5).
7. Pull out armature (6).
8. Remove screw holding the air vent protective screen. Remove protective screen.

Motor Assembly Notes

1. Apply gasket sealant between gearbox housing and the outside of the front armature housing.
2. If the armature does not turn freely after installation, the wrong gear teeth were engaged.
3. Hold armature in place when installing the magnet housing. Position magnet housing with the roll pin outward and pointed towards 8 o'clock. The square hole of the mounting plate should be positioned at 10 o'clock.
4. Install commutator brush assembly. Wires should be at the 9 o'clock position.
5. Insert magnet housing roll pin into the recess on the tail housing.

Capstan Removal

1. Use a 1-inch 18 point socket to remove capstan retaining bolt (11) and washer (19).
2. Pull the capstan (2) off of the shaft.

If the capstan is stuck: Pull out the rope ramp. Use two pry bars on opposite sides of the capstan between the gear housing and the capstan.

IMPORTANT

The first reduction hub will be damaged if the leads are reversed.

3. Remove key (24).
4. Remove rope ramp (3).

Capstan Assembly Notes

1. Remove oxidation before assembling.
2. **Do not hammer capstan onto shaft.** Use a 65 mm (2-1/2") or longer bolt to draw the capstan onto the shaft.



Maintenance (cont'd)

Right Angle Sheave Bracket Removal

1. Remove detent pin (22).
2. Slide arm towards motor. Use a small punch to remove the roll pin (20).
3. Remove bracket (4).

Gearbox Disassembly

1. Remove motor, capstan and right angle sheave bracket.
2. Remove the screws (38) on the motor side of the gearbox. Remove the mounting plate (20).
3. Remove the motor mounting housing (2).
4. Pull out the 1st reduction planet gear assembly and thrust washer.
5. Pull out the center shaft (12).
6. Pull out the 2nd reduction planet gear assembly and thrust washer.
7. Push out the output shaft/3rd reduction gear assembly and thrust washer.
8. Remove the screws holding the ring gear (37).
9. Tap the bearing housing off the ring gear and dowel pins. **Do not mar the mating surface to the ring gear.**

Gearbox Assembly Note

1. Clean all ring mating surfaces. Apply a flange sealant (Loctite® 515 or equivalent) to all ring mating surfaces.
2. Install center shaft with the small diameter towards the motor.
3. Install the mounting plates. When viewed from the motor end, the motor mounting studs should be positioned at 1 and 7 o'clock. The square hole in the mounting plate should be between 10 and 11 o'clock.
4. Position mounting plates so the screw heads on the capstan side fit into the counterbores of the mounting plates.

Disassembly of Planet Gear Carriers

1. Remove the flat head screws.
2. Tap or pry off the hub plate from the hub and dowel pins.
3. Remove the thrust washers, gears, thrust washers and shaft.
4. Remove sun gear ONLY if replacement is required.

Planet Gear Carrier Assembly

1. Place the shafts in the hub. The end with the flat should face outward.
2. The 1st planet reduction gears must be positioned with the gear end towards the capstan.
3. When replacing the 1st reduction gear bearing/clutch, the locked arrow direction must be counter-clockwise (when viewed from the gear end).
4. **When replacing the ball bearing on the output shaft, the thick side of the outer race must face the capstan.**
5. Use a removable thread-locking compound, such as Loctite® 242® Threadlocker or equivalent, on the #10 – 32 flat head screws (items 35 and 36 on the gearmotor). Follow the manufacturer's instructions for curing.



Exploded View and Wiring Diagram – Ultra Tugger

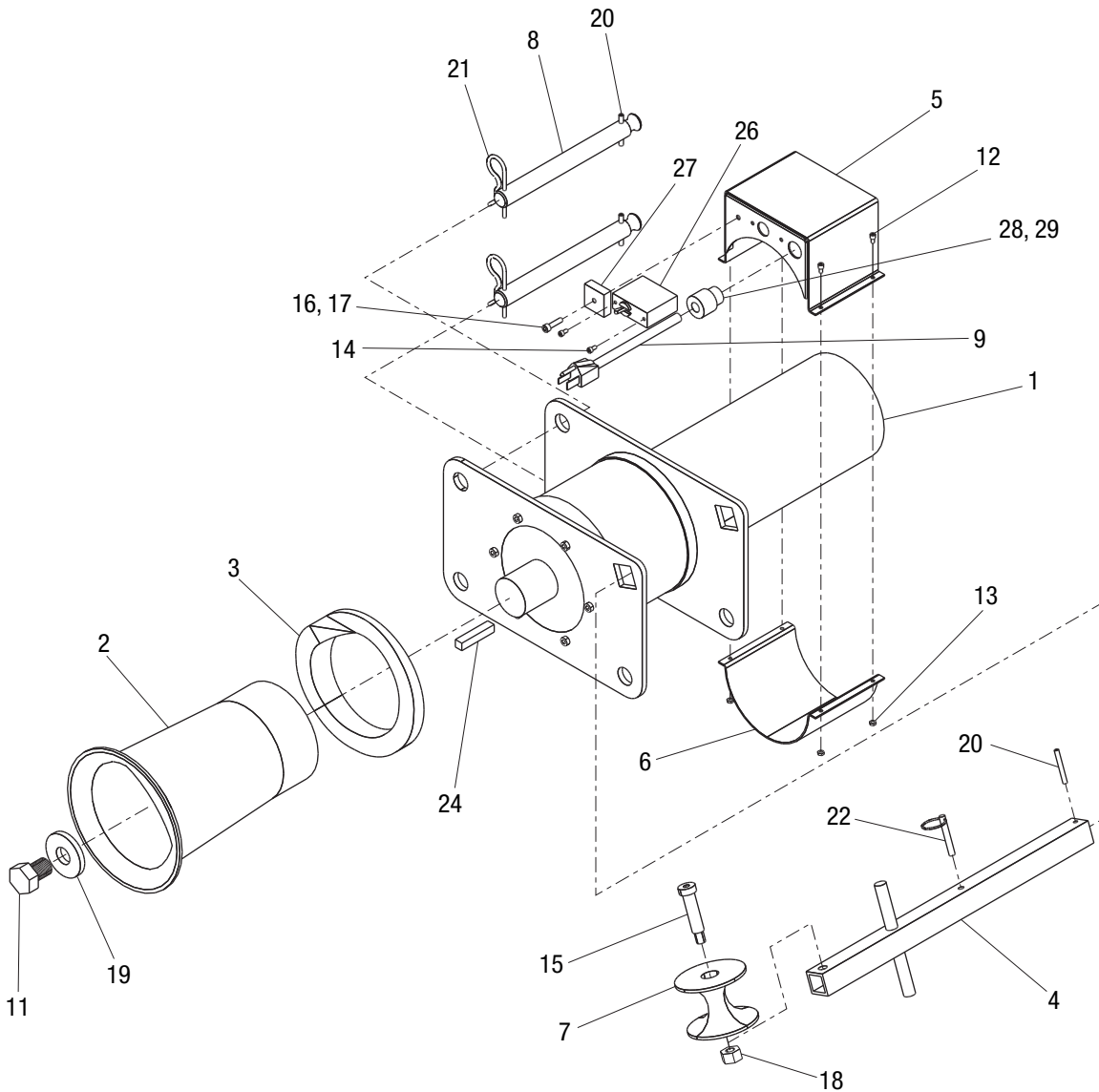
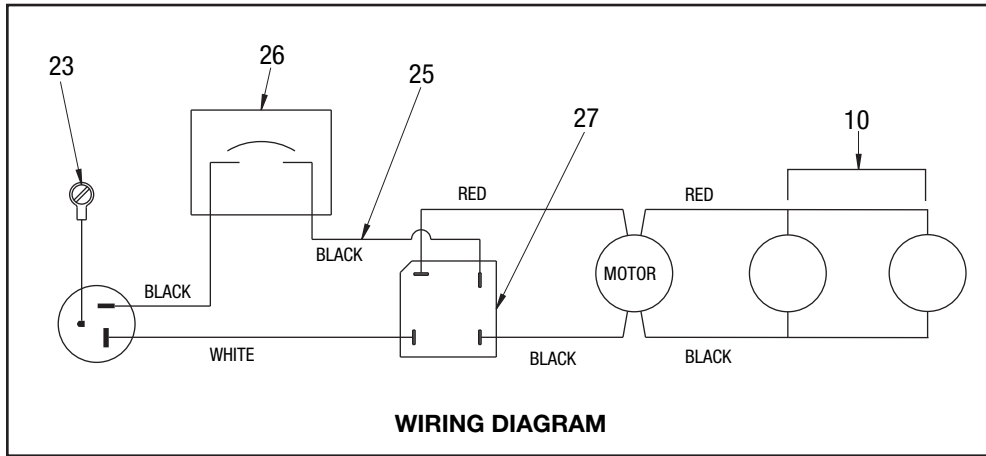



Parts List—Ultra Tugger

Key	Part No.	Description	Qty
1	50006460	Gearmotor.....	1
2	50007440	Capstan.....	1
3	50007513	Ramp, rope.....	1
4	50007416	Bar, tie.....	1
5	50007491	Switchbox.....	1
6	50007505	Clamp.....	1
7	50353110	Sheave, right angle.....	1
8*	50007432	Puller pin.....	2
9	50008757	Cord unit, power.....	1
10	50006690	Capacitor unit.....	1
11	90548485	Screw, cap, 3/4 – 16 x 1.500" hex head, grade 5.....	1
12	90502787	Screw, cap, #6 – 32 x .500" socket head.....	4
13	90548493	Nut, hex, #6 – 32.....	4
14	90522036	Screw, machine, #6 – 32 x .250" round head.....	2
15	90539214	Screw, shoulder, .5/8 x 1-3/4 x 1/2 – 13.....	1
16	90524918	Screw, machine, #10 – 24 x .750" round head.....	1
17	90533453	Nut, hex, #10 – 24 lock, zinc-plated.....	1
18	90527941	Nut, hex, 1/2 – 13 zinc-plated.....	1
19	90548507	Washer, flat, .780 x 2.000 x .250".....	2
20*	90507002	Pin, roll, .187" x 1.50".....	3
21*	90503023	Clip, hitch pin, #8.....	2
22	90548523	Hitch pin, Rein Leitzke #30 – 07.....	1
23	90533305	Screw, machine, #8 – 32 x .328" hex head, green.....	1
24	90548515	Key, square, .375" x 1.88".....	1
25	50008765	Wire unit.....	1
26	91871328	Switch / circuit breaker.....	1
27	91868130	Rectifier, 50 amp, bridge.....	1
28	90541243	Bushing, strain relief.....	1
29	91862639	Nut, conduit, 1/2" lock.....	1

Repair Kit

* 50061887	Kit, puller pin (includes one each of the items marked with an asterisk).....	2
------------	----------------------------------------------------------------------------------	---

Decals

50010298	Decal, warning.....	1
50010590	Decal, read IM.....	1
99935767	Decal, technical assistance.....	1



Exploded View—Gearmotor (50006460)

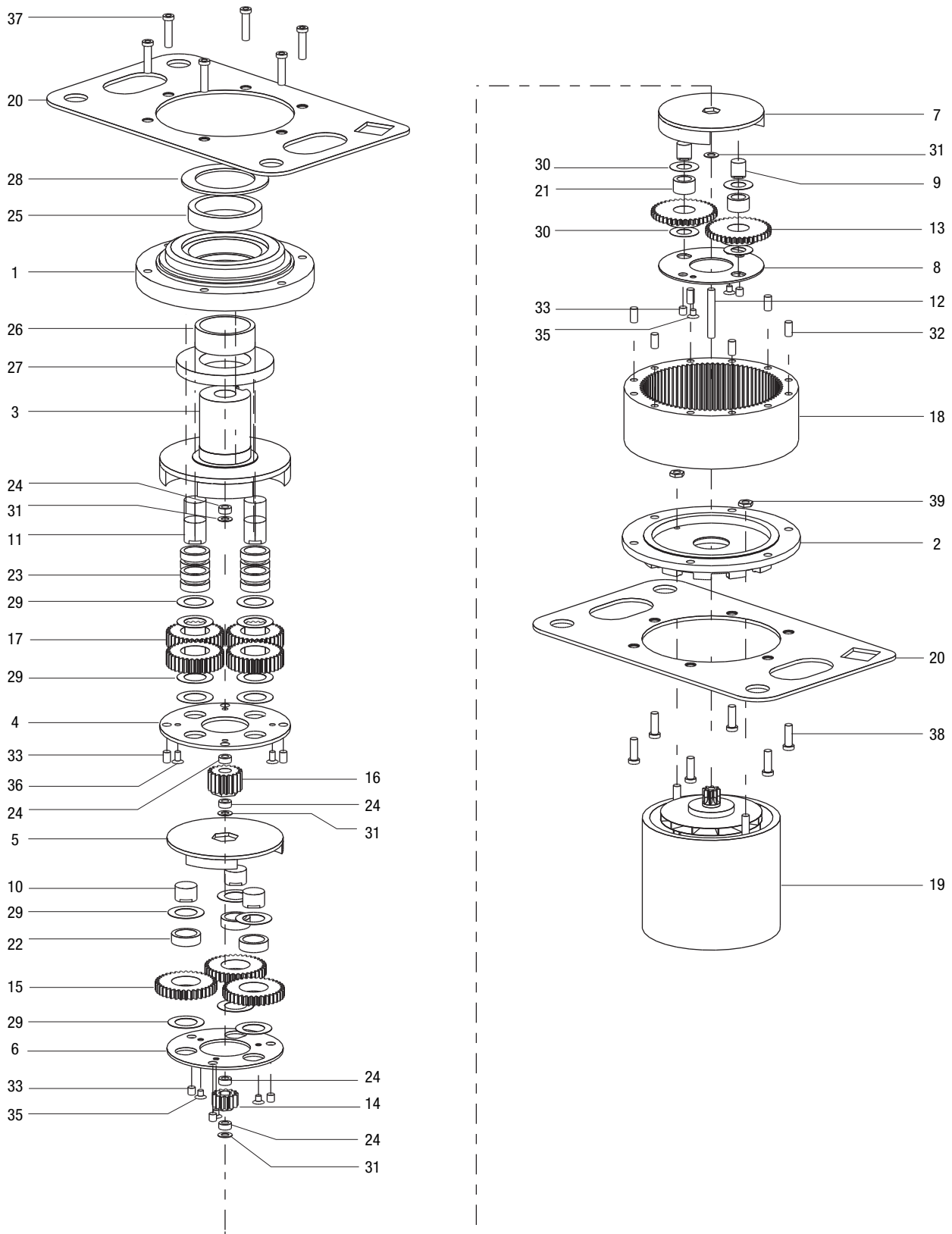



Parts List—Gearmotor (50006460)

Key	Part No.	Description	Qty
1	50006657	Bearing housing	1
2	50006630	Motor mount	1
3	50006576	Output hub	1
4	50006584	Output hub plate	1
5	50006622	2nd reduction hub	1
6	50006592	2nd reduction hub plate	1
7	50006606	1st reduction hub	1
8	50006517	1st reduction hub plate	1
9	50006487	1st reduction shaft	2
10	50006495	2nd reduction shaft	3
11	50006509	3rd reduction shaft	4
12	50006479	Center shaft	1
13	50006525	1st reduction planet gear	2
14	50006533	2nd reduction sun gear	1
15	50006541	2nd reduction planet gear	3
16	50006550	3rd reduction sun gear	1
17	50006568	3rd reduction planet gear	4
18	50006614	Ring gear	1
19	50006649	Motor	1
20	50006665	Motor mounting plate	2
21	90548230	Clutch, Torrington #RCB-081214	2
22	90548248	Bearing, Torrington #B-1210	3
23	90548256	Bearing, Torrington #B-128	8
24	90548264	Bearing, Torrington #B-46	5
25	90548272	Bearing, Torrington #BH-3316	1
26	90548280	Inner race, Torrington #IR-2824	1
27	90548299	Bearing, Fafnir #7209W	1
28	90548302	Seal, Freudenberg-Nok #UF-0216E	1
29	90548329	Thrust washer, .760 x 1.25 x .020"	14
30	90548310	Thrust washer, .510 x 1.00 x .020"	4
31	90548337	Thrust washer, .260 x .50 x .030"	8
32	90534719	Dowel pin, .250 x 1.250"	6
33	90541036	Dowel pin, .312 x .625"	9
35	90548345	Screw, cap, #8–32 x .500", socket flat head	5
36	90548353	Screw, cap, #8–32 x .750", socket flat head	4
37	90548361	Screw, cap, 1/4 – 28 x 2.00", socket head	6
38	90501535	Screw, cap, 1/4 – 28 x 1.500", socket head	6
39	90521080	Nut, hex, 1/4 – 20	2

Repair Kits

- 50022920 Gearmotor repair group #1
(includes 3, 4, 11, 17, 23, 24[2], 29[2], 33, 36)
- 50022954 Gearmotor repair group #2
(includes 5, 6, 10, 15, 16, 22, 24, 29[2], 34, 35)
- 50022970 Gearmotor repair group #3
(includes 7-9, 13, 14, 21, 24, 30[2], 31, 34, 35)

Exploded View—Motor (50006649)

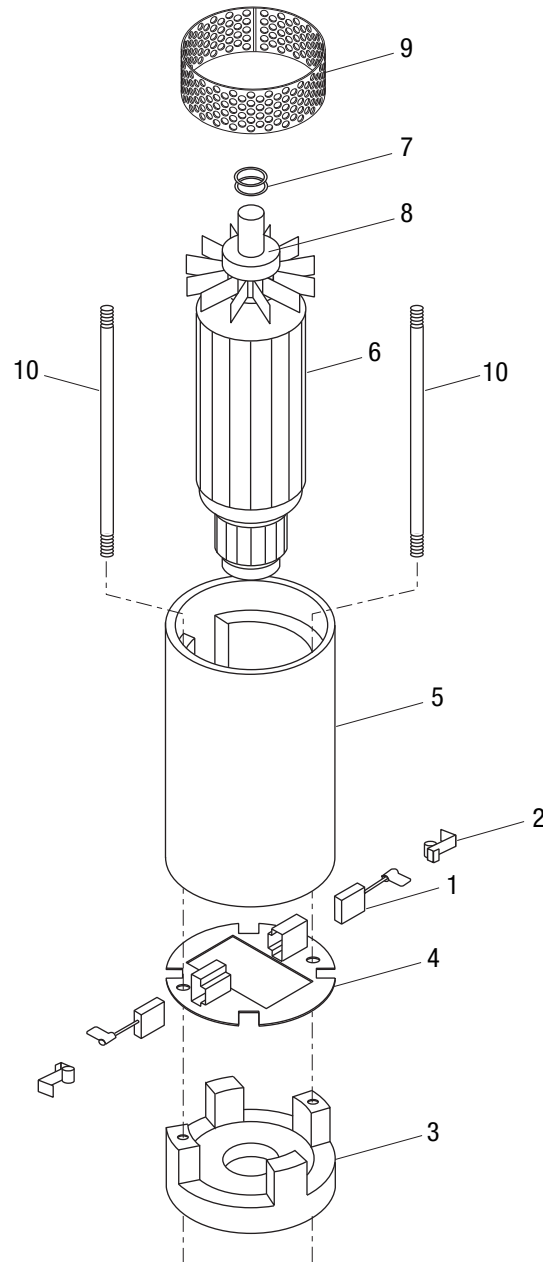

Key	Part No.	Description	Qty
	50006649	Motor	
1	91867053	Commutator brushes	2
2	91867061	Commutator brush retention spring.....	2
3	91865590	Tail housing	1
4	91865603	Brush assembly plate.....	1
5	91865611	Magnet housing	1
6	91865620	Armature	1
7	90543483	Belleville washers.....	2
8	91860717	Bearing.....	1
9	91869218	Screen.....	1
10	91869145	Threaded rod.....	2



Exploded View—Force Gauge (50010697)

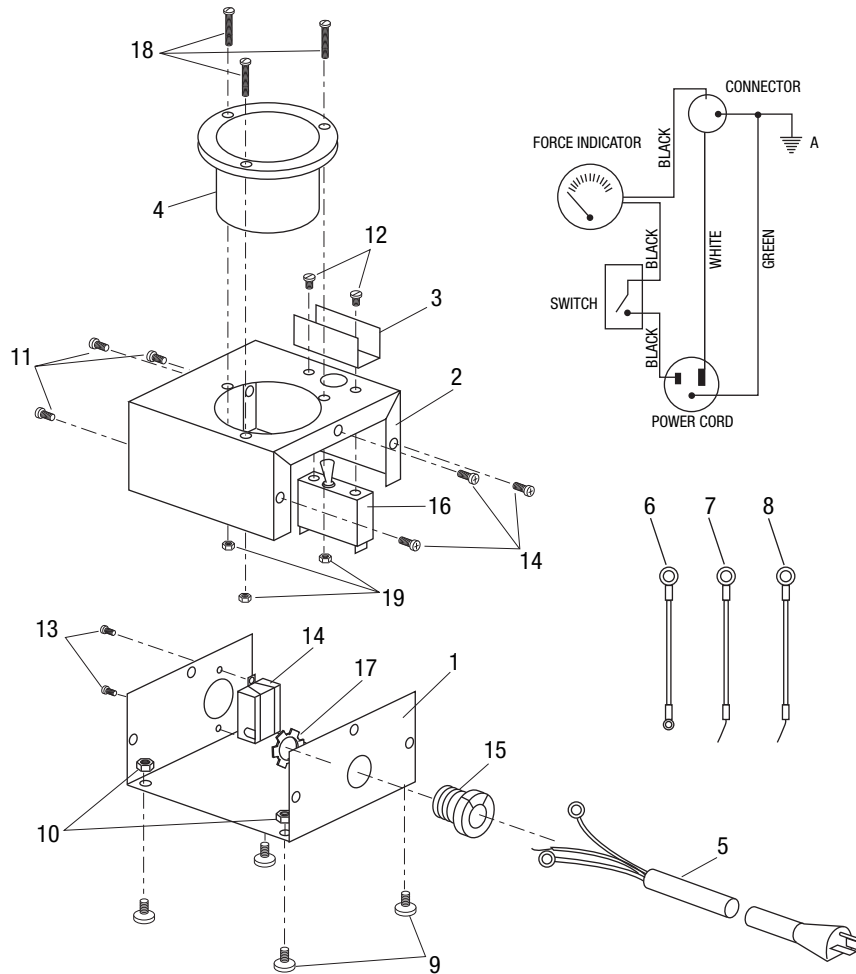

Key	Part No.	Description	Qty
1	50371088	Box, lower	1
2	50371070	Box, upper	1
3	50297082	Guard, switch	1
4	50010760	Meter	1
5	50371703	Cord, power	1
6	50371622	Wire unit, 12 AWG x 3.00", black.....	1
7	50371630	Wire unit, 12 AWG x 7.00", black.....	1
8	50371649	Wire unit, 12 AWG x 4.00", green	1
9	90539346	Bumper, #8 – 32 machine screw, rubber	4
10	90506332	Nut, hex, #8 – 32	4
11	90531949	Screw, self-tapping, #10 – 16 x .250 Phillips head	6
12	90522036	Screw, machine, #6 – 32 x .25", slotted pan head	2
13	90514408	Screw, machine, #8 – 32 x .375", round head	2
14	91866847	Receptacle, 20 amp female	1
15	90541243	Bushing, strain relief.....	1
16	91863830	Switch	1
17	91862639	Nut, conduit, 1/2" lock	1
18	90537254	Screw, cap, #6 – 32 x .750", socket button head	3
19	90506324	Nut, hex, #6 – 32.....	3

Decals

50303929	Decal, damp warning	1
50010719	Decal, identification.....	1

Accessories

Slip-in Couplers

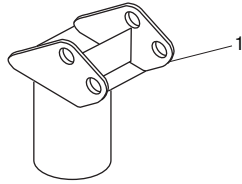

Key	Part No.	Description	Qty
1	50008048	Slip-in coupler for 2-1/2" conduit (EMT, IMC or Rigid)	1
1	50008110	Slip-in coupler for 3" conduit (EMT, IMC or Rigid).....	1
1	50008153	Slip-in coupler for 3-1/2" conduit (EMT, IMC or Rigid)	1
1	50008200	Slip-in coupler for 4" conduit (EMT, IMC or Rigid).....	1
1	50008277	Slip-in coupler for 5" conduit (EMT, IMC or Rigid).....	1

Screw-on Couplers

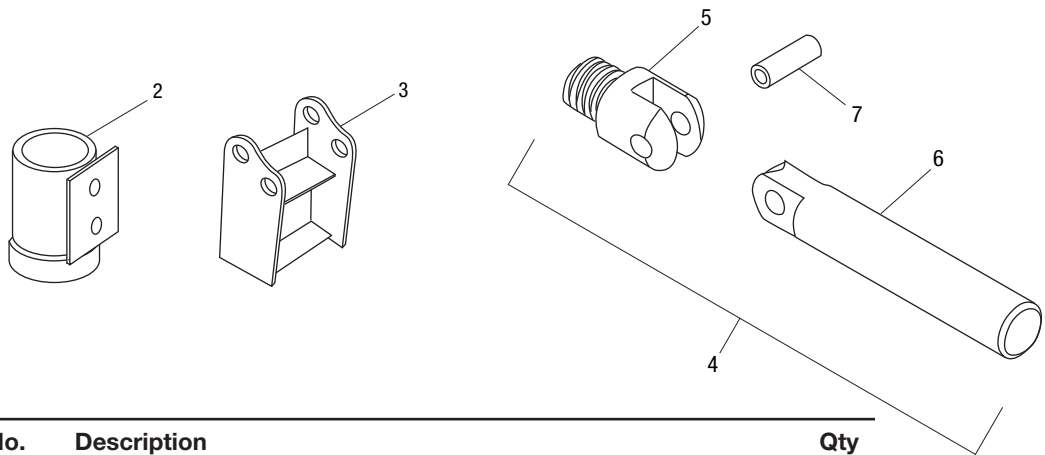

Key	Part No.	Description	Qty
—	50008684	Screw-on coupler set for 2-1/2", 3", 3-1/2" & 4" conduit (includes items 2, 3, and 4)	
2	50036610	Screw-on coupler for 2" IMC or Rigid only	1
2	50007815	Screw-on coupler for 2-1/2" IMC or Rigid only	1
2	50007823	Screw-on coupler for 3" IMC or Rigid only	1
2	50007831	Screw-on coupler for 3-1/2" IMC or Rigid only	1
2	50007840	Screw-on coupler for 4" IMC or Rigid only	1
3	50007998	Adapter for screw-on IMC or Rigid only	1
4	50008773	Screw assembly (includes items 5, 6 and 7).....	2
5	50007955	Screw.....	1
6	50007963	Handle	1
7	90527178	Roll pin.....	1

Boom Tubes

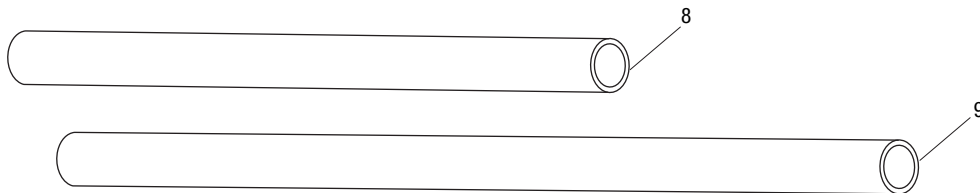

Key	Part No.	Description	Qty
8	50008358	3' Boom tube	1
9	50007912	4' Boom tube	1



Accessories (cont'd)

T-Stand (50008676)

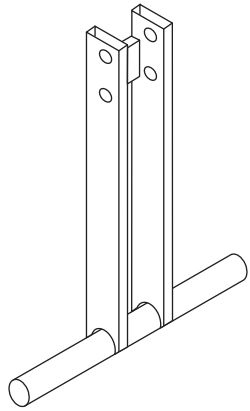

Wheeled Carriage (50008706)

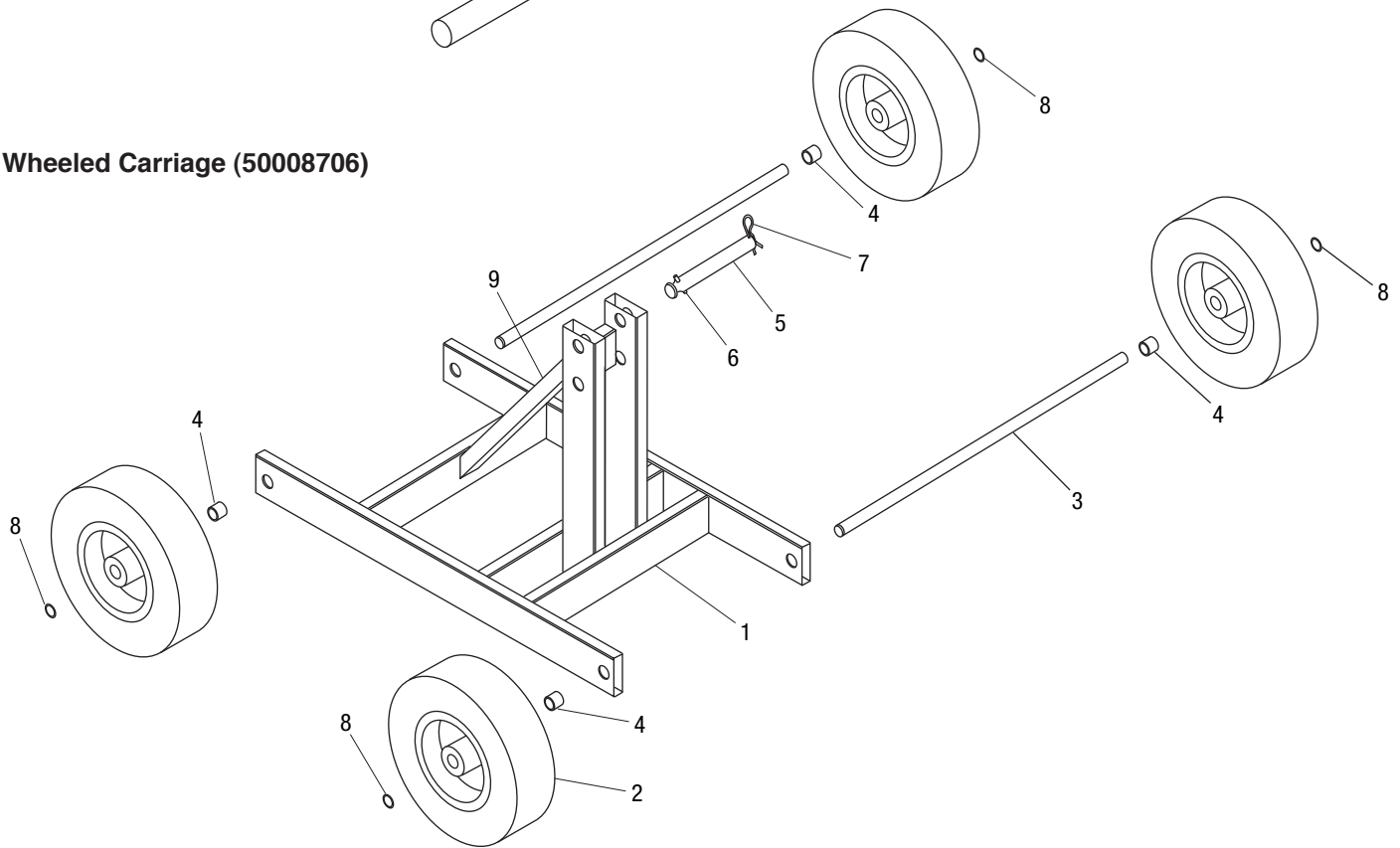

Key	Part No.	Description	Qty
1	50007700	Frame	1
2	90548396	Wheel, 4.10/3.50 – 6 x 3/4 shaft, 3" hub length.....	4
3	50007688	Axle	2
4	50320262	Spacer, .824 x 1.05 x .750"	4
5*	50007432	Puller pin	2
6*	90507002	Pin, roll, .187 x 1.50"	2
7*	90503023	Clip, hitch pin #8.....	2
8	90515285	Retaining ring, .750", Truarc #5160-75-S-PP	4
9	50010638	Decal, warning	1

Repair Kit

*	50061887	Kit, puller pin (includes one each of the items marked with an asterisk)	2
---	----------	-----------------------------------------------------------------------------------	---

Accessories (cont'd)

Boom Mount (50008714)

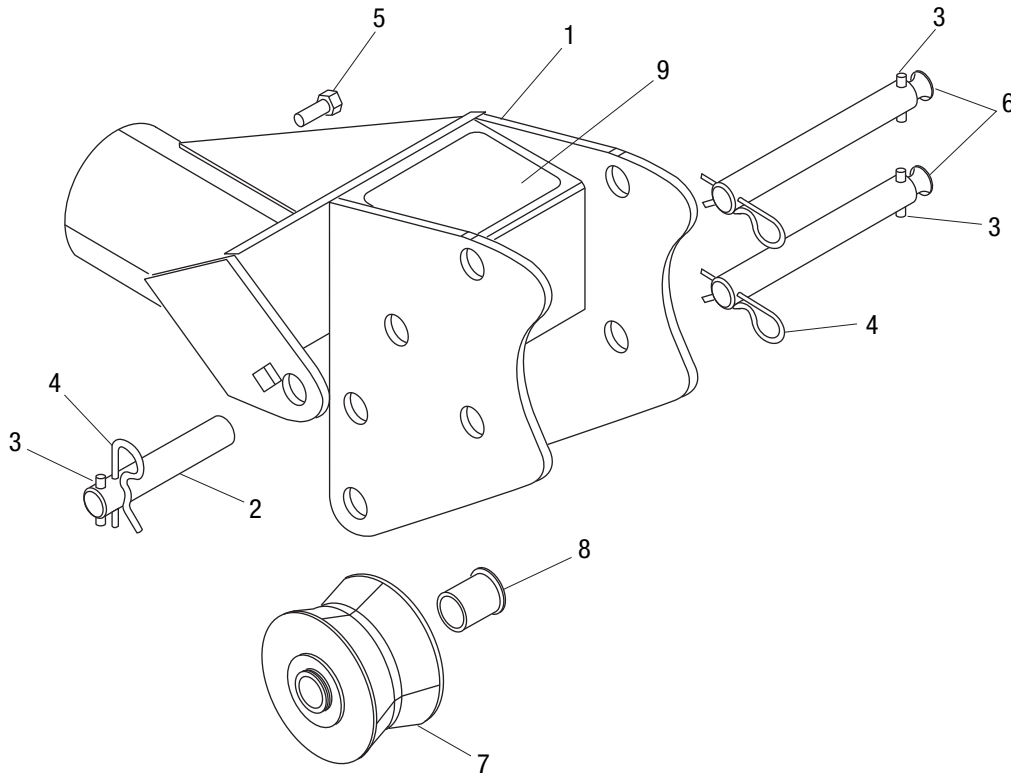

Key	Part No.	Description	Qty
1	50007610	Frame	1
2 +	50007556	Shaft.....	1
3* +	90507002	Pin, roll, .187 x 1.50"	3
4* +	90503023	Clip, hitch pin #8	3
5	90505301	Screw, cap, 3/8 – 16 x 1.000" hex head	1
6*	50007432	Puller pin	2
7	50009206	Wheel unit, idler	1
8	50167987	Bushing.....	2
9	50010310	Decal, warning	1

Repair Kits

*	50061887	Kit, puller pin (includes one each of the items marked with an asterisk)	2
+	50061917	Kit, shaft (includes one each of the items marked with a plus sign).....	1



Accessories (cont'd)

Nose Unit (50008641)

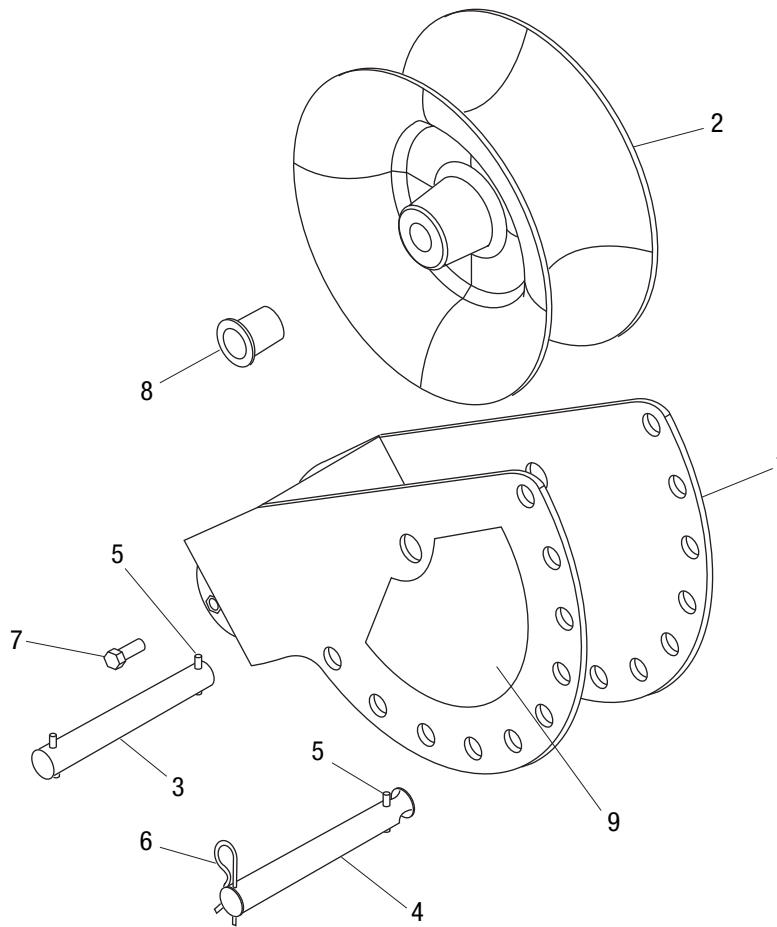

Key	Part No.	Description	Qty
1	50008323	Elbow, adjustable.....	1
2	50008439	Sheave unit, 12".....	1
3	50007904	Shaft, elbow.....	1
4	50007432	Puller pin.....	1
5*	90507002	Pin, roll, .187 x 1.50".....	3
6*	90503023	Clip, hitch pin #8.....	1
7	90505301	Screw, cap, 3/8 – 16 x 1.000" hex head.....	1
8	90548388	Bushing.....	2
9	50010425	Decal, warning.....	1

Repair Kit

*	50061887	Kit, puller pin (includes one each of the items marked with an asterisk).....	2
	50061925	Kit, elbow shaft (includes one of item 3 and two of item 5).....	2

Accessories (cont'd)

Elbow Unit (50008633)

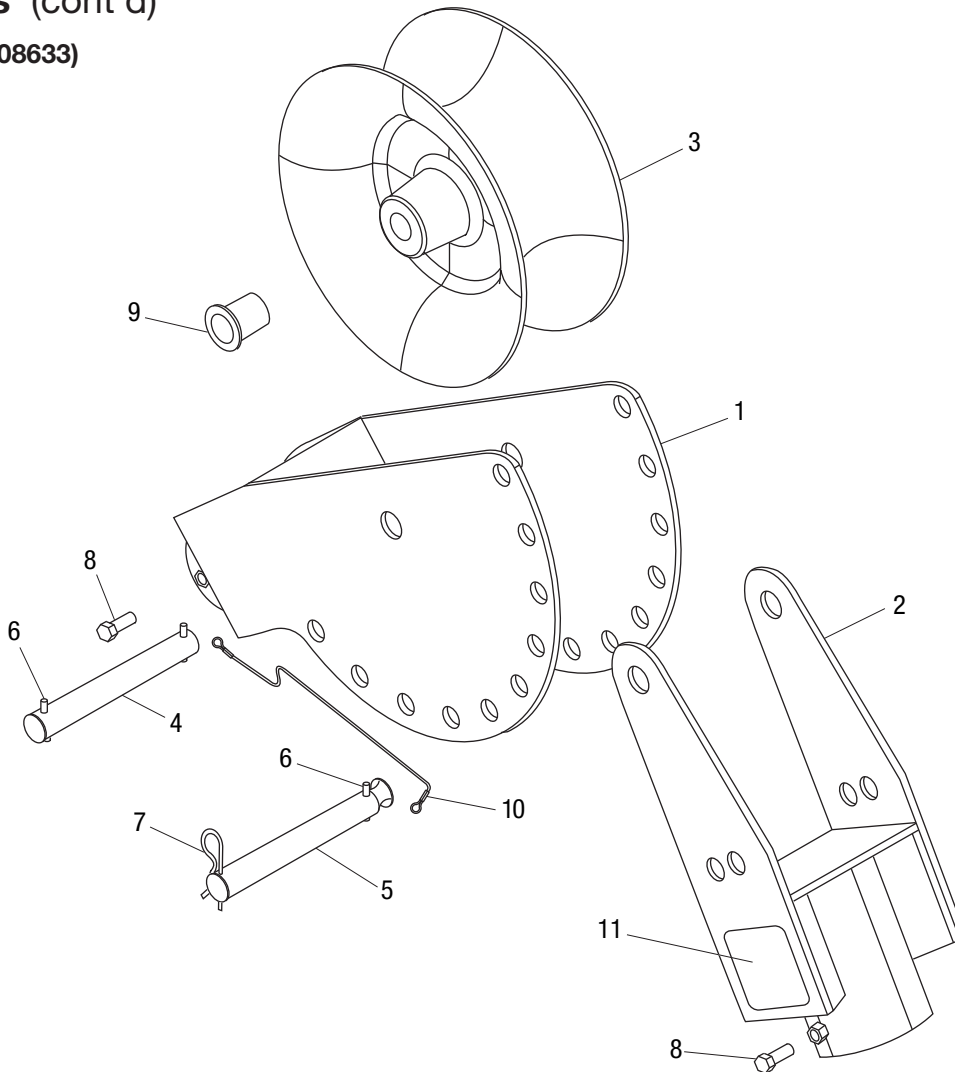

Key	Part No.	Description	Qty
1	50008323	Elbow, adjustable.....	1
2	50008285	Elbow, pivot.....	1
3	50008439	Sheave unit, 12".....	1
4	50008366	Shaft, pivot.....	1
5*	50008374	Pin, elbow.....	1
6*	90507002	Pin, roll, .187 x 1.50".....	3
7*	90503023	Clip, hitch pin #8.....	1
8	90505301	Screw, cap, 3/8 – 16 x 1.000" hex head.....	2
9	90548388	Bushing.....	2
10	50013971	Lanyard.....	1
11	50010328	Decal, warning.....	1

Repair Kits

*	50061941	Kit, elbow pins (includes one each of the items marked with an asterisk).....	1
	50061950	Kit, pivot pins (includes one of item 4 and two of item 6).....	1



Accessories (cont'd)

Floor Mount (50008650)

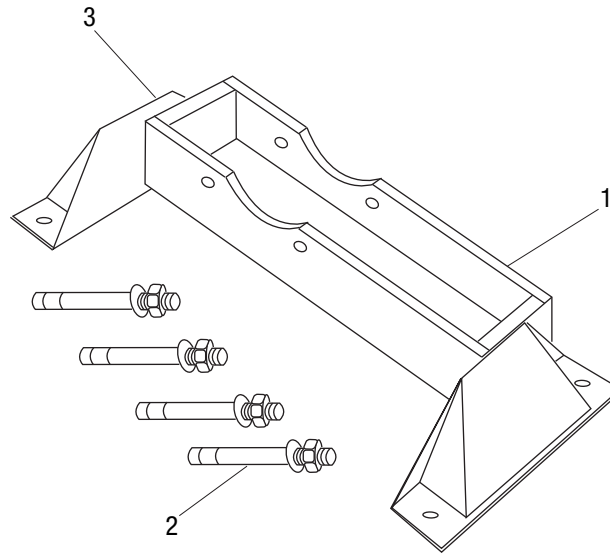

Key	Part No.	Description	Qty
1	50007890	Frame	1
2	50356070	Anchor, wedge, .625 x 6.00"	4
3	50010476	Decal, warning	1

Accessories (cont'd)

Chain Mount (50028464)

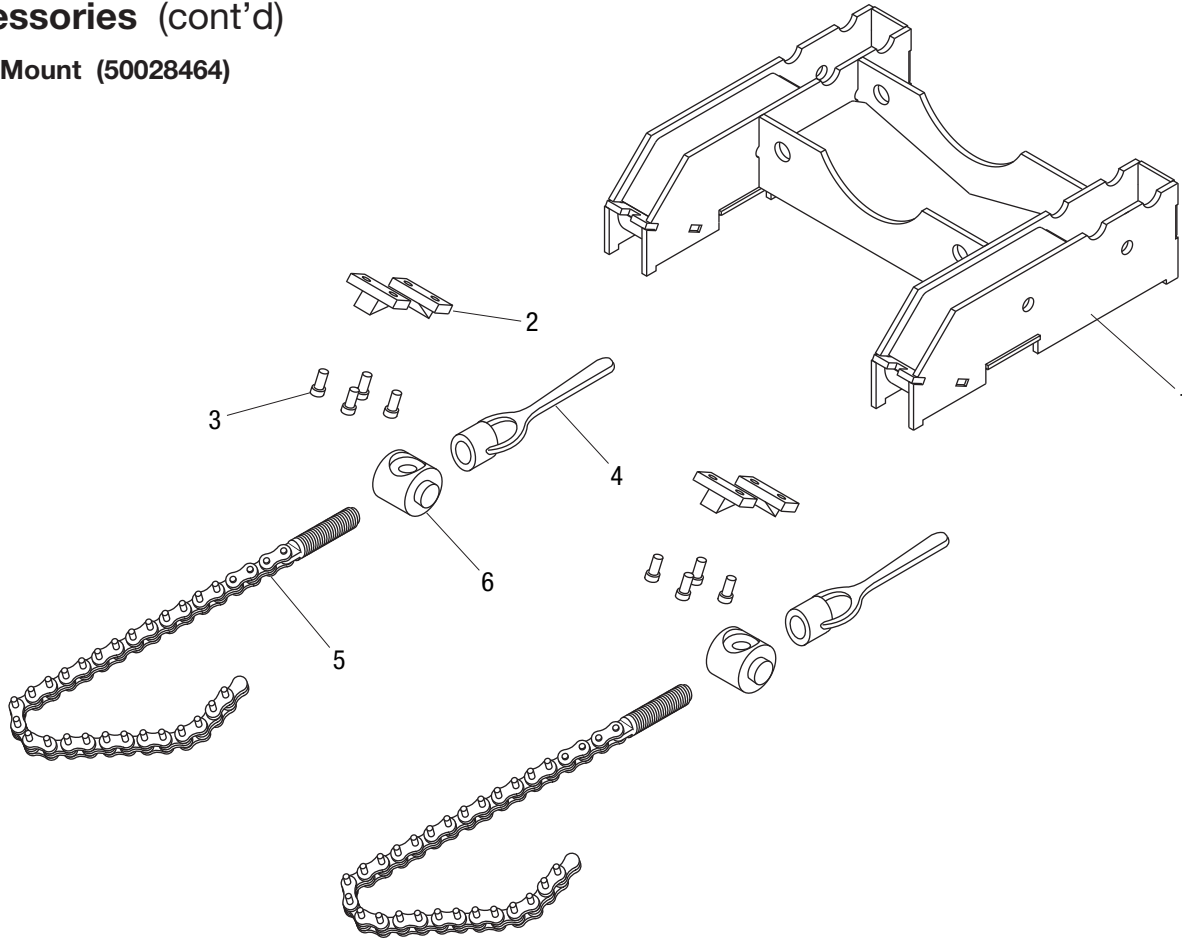

Key	Part No.	Description	Qty
1	50111639	Frame	1
2	50296647	Foot	4
3	90505794	Screw, cap, 1/4 – 20 x .500", socket head	8
4	50296302	Handle unit, vise chain	2
5	50256615	Screw unit, vise chain	2
6	50007734	Block, pivot	2
	50010514	Decal, warning (not shown).....	1



USA	800-435-0786	Fax: 800-451-2632
	815-397-7070	Fax: 815-397-1865
Canada	800-435-0786	Fax: 800-524-2853
International	+1-815-397-7070	Fax: +1-815-397-9247

4455 Boeing Drive • Rockford, IL 61109-2988 • USA • 815-397-7070
 An ISO 9001 Company • Greenlee Textron Inc. is a subsidiary of Textron Inc.

www.greenlee.com

Printed in USA